

AP2035G

N-Channel Enhancement Mosfet

AIIPOWER

DATA SHEET

Feature

- 20V,70A
 $R_{DS(ON)} < 4m\Omega @ V_{GS}=4.5V$ TYP=3.1 m Ω
 $R_{DS(ON)} < 5.8m\Omega @ V_{GS}=2.5V$ TYP=4.0 m Ω
- Advanced Trench Technology
- Lead free product is acquired
- Excellent $R_{DS(ON)}$ and Low Gate Charge

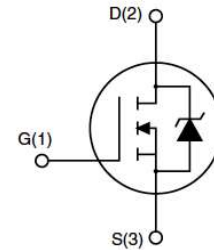

Application

- PWM applications
- Load Switch
- Power management

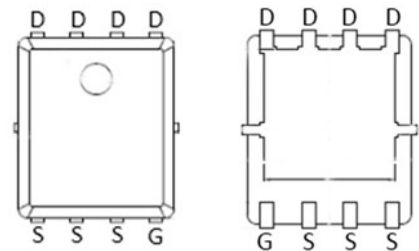

PDFN5X6-8L

Package Marking and Ordering Information

Device Marking	Device	Device Package	Reel Size	Tape width	Quantity (PCS)
2035G	AP2035G	PDFN5X6	13 inch	-	5000

ABSOLUTE MAXIMUM RATINGS ($T_a=25^\circ\text{C}$ unless otherwise noted)

Parameter	Symbol	Value	Unit
Drain-Source Voltage	V_{DS}	20	V
Gate-Source Voltage	V_{GS}	± 12	V
Continuous Drain Current ($T_a=25^\circ\text{C}$)	I_D	70	A
Continuous Drain Current ($T_a=100^\circ\text{C}$)	I_D	52	A
Pulsed Drain Current ⁽¹⁾	I_{DM}	220	A
Singel Pulsed Avalanche Energy ⁽²⁾	E_{AS}	88	mJ
Power Dissipation	P_D	45	W
Thermal Resistance from Junction to Case ⁽⁴⁾	$R_{\theta JC}$	2.7	$^\circ\text{C}/\text{W}$
Junction Temperature	T_J	150	$^\circ\text{C}$
Storage Temperature	T_{STG}	-55~ +150	$^\circ\text{C}$

MOSFET ELECTRICAL CHARACTERISTICS($T_a=25^\circ\text{C}$ unless otherwise noted)

Parameter	Symbol	Test Condition	Min	Type	Max	Unit
Static Characteristics						
Drain-source breakdown voltage	$V_{(BR)DSS}$	$V_{GS} = 0V, I_D = 250\mu A$	20	-	-	V
Zero gate voltage drain current	I_{DSS}	$V_{DS} = 20V, V_{GS} = 0V$	-	-	1	μA
Gate-body leakage current	I_{GSS}	$V_{GS} = \pm 12V, V_{DS} = 0V$	-	-	± 100	nA
Gate threshold voltage ⁽³⁾	$V_{GS(th)}$	$V_{DS} = V_{GS}, I_D = 250\mu A$	0.5	0.7	0.9	V
Drain-source on-resistance ⁽³⁾	$R_{DS(on)}$	$V_{GS} = 4.5V, I_D = 30A$	-	3.1	4.0	m Ω
		$V_{GS} = 2.5V, I_D = 20A$	-	4.0	5.8	
Dynamic characteristics						
Input Capacitance	C_{iss}	$V_{DS} = 10V, V_{GS} = 0V, f = 1MHz$	-	2560	-	pF
Output Capacitance	C_{oss}		-	368	-	
Reverse Transfer Capacitance	C_{rss}		-	356	-	
Switching characteristics						
Turn-on delay time	$t_{d(on)}$	$V_{DD} = 10V, I_D = 30A,$ $V_{GS} = 4.5V, R_G = 1.8\Omega$	-	7.8	-	ns
Turn-on rise time	t_r		-	30	-	
Turn-off delay time	$t_{d(off)}$		-	50	-	
Turn-off fall time	t_f		-	42	-	
Total Gate Charge	Q_g	$V_{DS} = 10V, I_D = 30A,$ $V_{GS} = 4.5V$	-	38	-	nC
Gate-Source Charge	Q_{gs}		-	2.9	-	
Gate-Drain Charge	Q_{gd}		-	15	-	
Source-Drain Diode characteristics						
Diode Forward voltage ⁽³⁾	V_{DS}	$V_{GS} = 0V, I_S = 30A$	-	-	1.2	V
Diode Forward current ⁽⁴⁾	I_S		-	-	70	A

Notes:

1. Repetitive Rating: pulse width limited by maximum junction temperature
2. EAS Condition: $T_J = 25^\circ\text{C}, V_{DD} = 15V, R_G = 25\Omega, L = 0.5\text{mH}$
3. Pulse Test: pulse width $\leq 300\mu\text{s}$, duty cycle $\leq 2\%$
4. Surface Mounted on FR4 Board, $t \leq 10\text{ sec}$

Test Circuit & Waveform

Gate Charge Test Circuit & Waveform

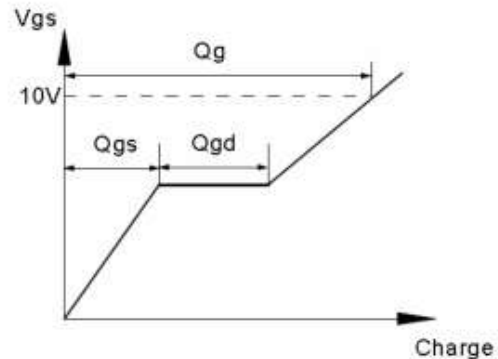
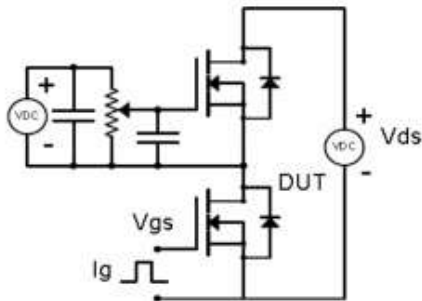

Resistive Switching Test Circuit & Waveforms

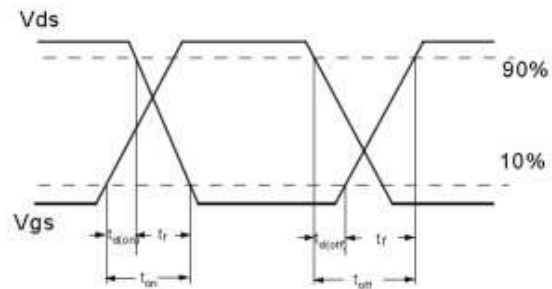
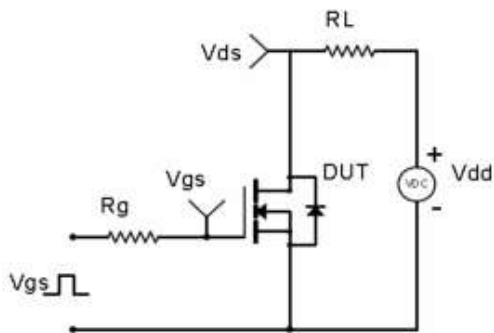

Unclamped Inductive Switching (UIS) Test Circuit & Waveforms

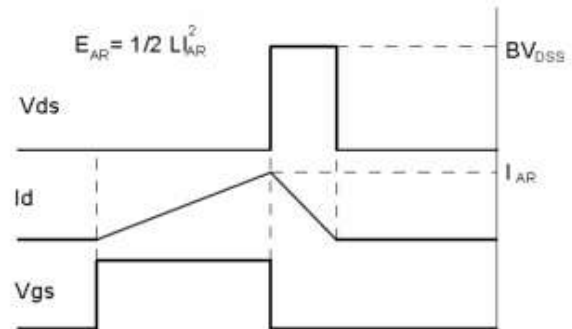
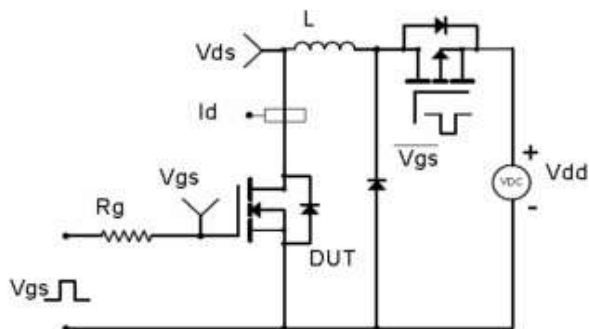

Diode Recovery Test Circuit & Waveforms

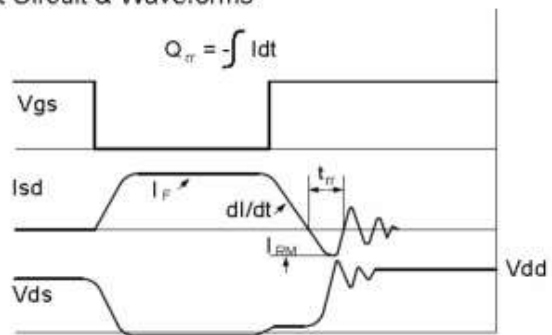
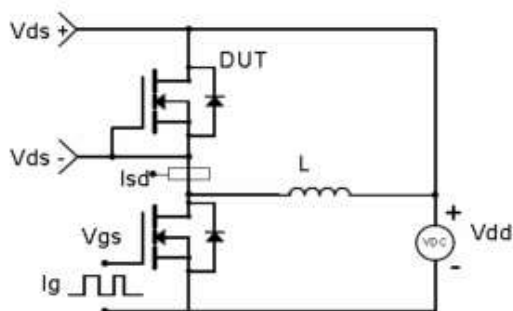

Figure 1: Output Characteristics

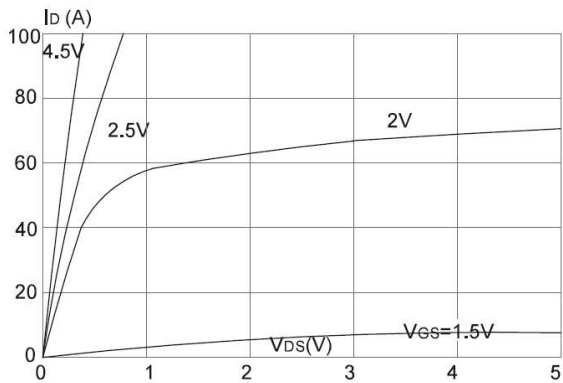

Figure 2: Typical Transfer Characteristics

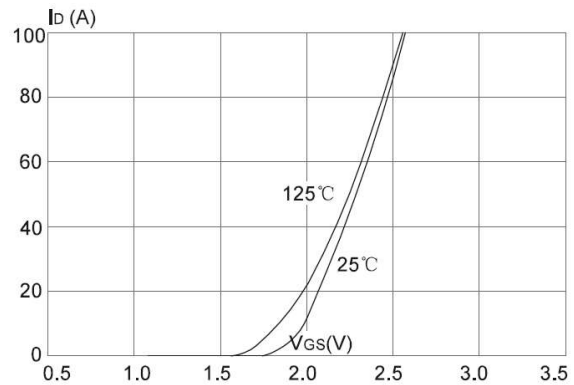

Figure 3: On-resistance vs. Drain Current

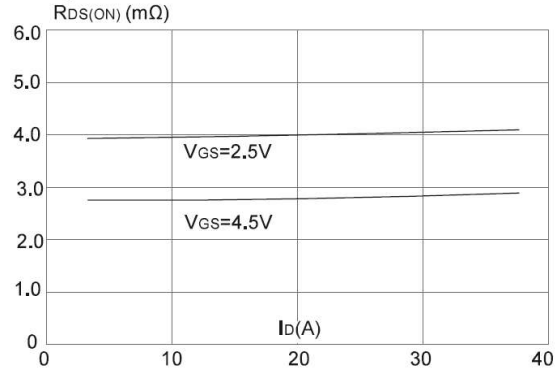

Figure 4: Body Diode Characteristics

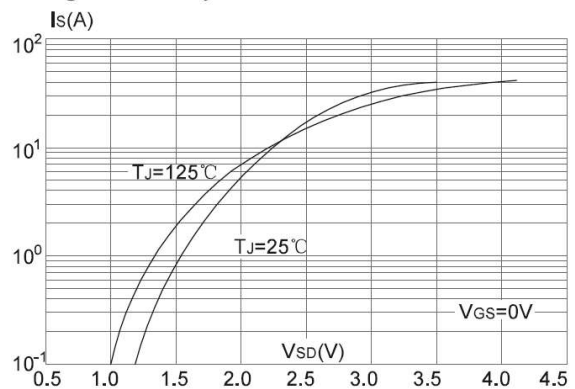

Figure 5: Gate Charge Characteristics

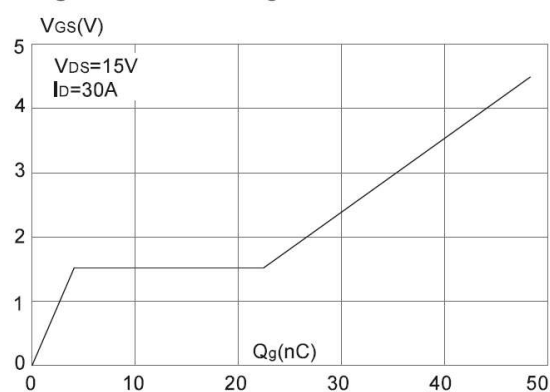

Figure 6: Capacitance Characteristics

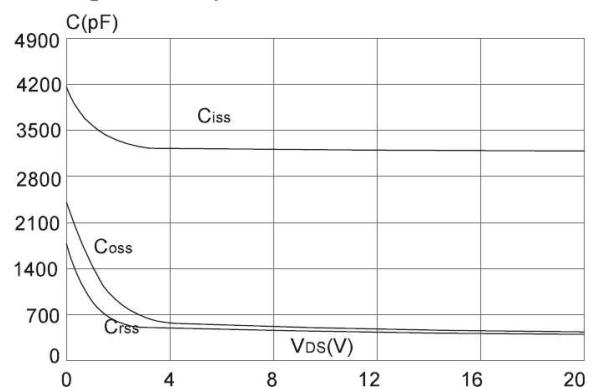

Figure 7: Normalized Breakdown Voltage vs. Junction Temperature

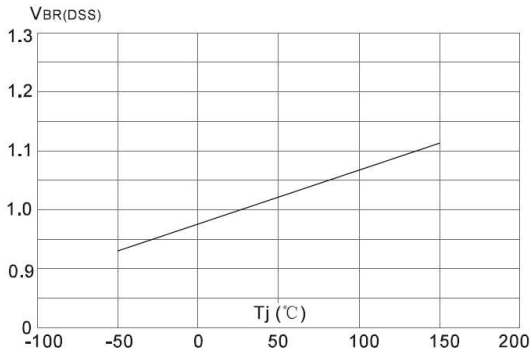

Figure 8: Normalized on Resistance vs. Junction Temperature

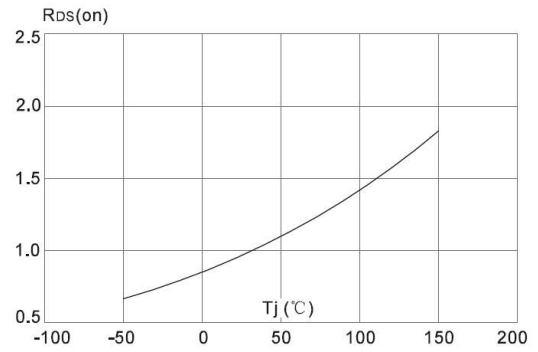

Figure.9: Maximum Drain Current vs. Case Temperature

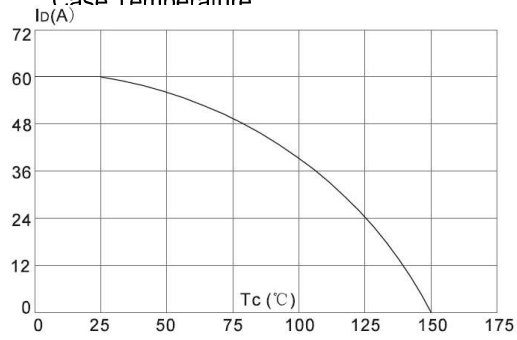

Fig.10 Safe Operating Area

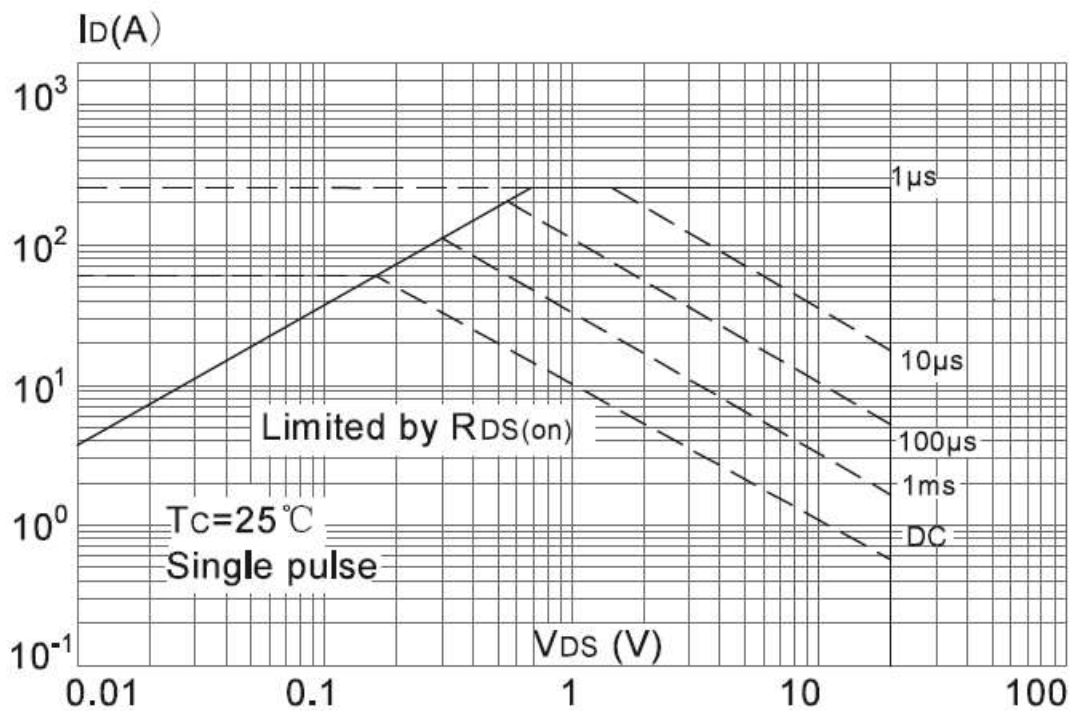
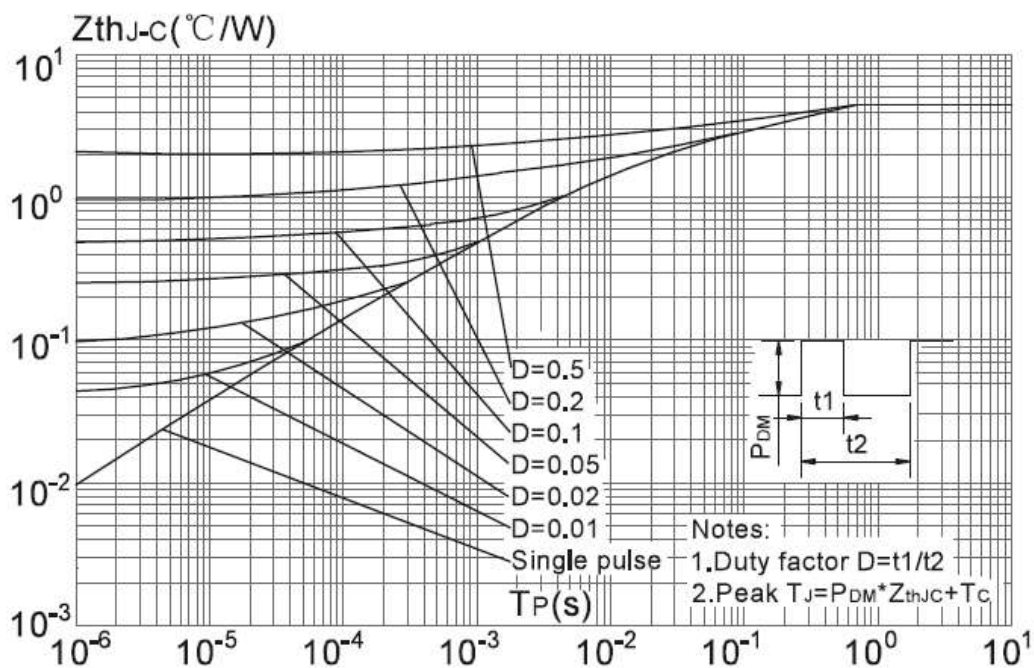

Fig. 11 Transient Thermal Response Curve



AP2035G

N-Channel Enhancement Mosfet

PDFN5X6 Package Information

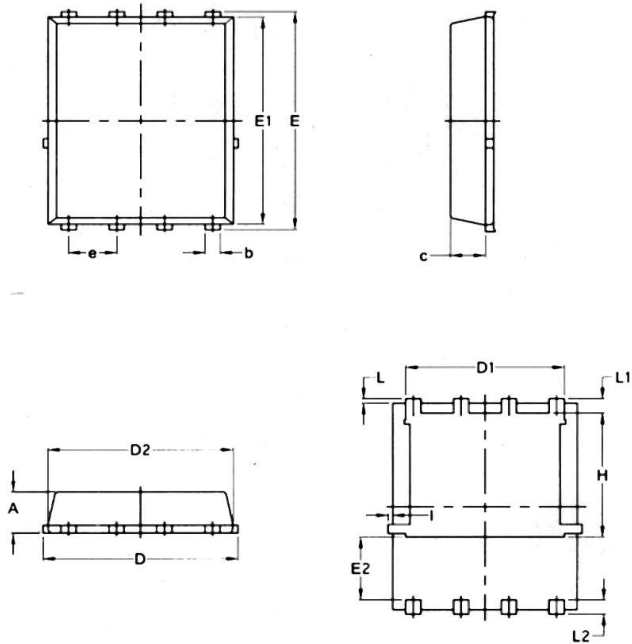

PDFN5X6

SYMBOL	COMMON			
	MM		INCH	
	MIN.	MAX.	MIN.	MAX.
A	1.03	1.17	0.0406	0.0461
b	0.34	0.48	0.0134	0.0189
c	0.824	0.970	0.0324	0.0382
D	4.80	5.40	0.1890	0.2126
D1	4.11	4.31	0.1618	0.1697
D2	4.80	5.00	0.1890	0.1969
E	5.95	6.15	0.2343	0.2421
E1	5.65	5.85	0.2224	0.2303
E2	1.60	—	0.0630	—
e	1.27 BSC		0.05 BSC	
L	0.05	0.25	0.0020	0.0098
L1	0.38	0.50	0.0150	0.0197
L2	0.38	0.50	0.0150	0.0197
H	3.30	3.50	0.1299	0.1378
I	—	0.18	—	0.0070