

# AP60N04G

N-Channel Enhancement Mosfet

# AIIPOWER

## DATA SHEET

### Feature

- 40V,40A  
 $R_{DS(ON)} < 9.3m\Omega @ V_{GS}=10V$  TYP:7.4 m $\Omega$   
 $R_{DS(ON)} < 14.3m\Omega @ V_{GS}=4.5V$  TYP:10.4 m $\Omega$
- Advanced Trench Technology
- Lead free product is acquired
- Excellent  $R_{DS(ON)}$  and Low Gate Charge

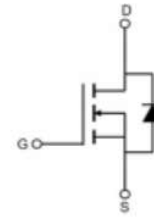

Schematic Diagram

### Application

- PWM applications
- Load Switch
- Power management

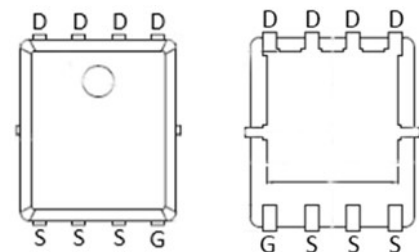

PDFN5X6-8L

### Package Marking and Ordering Information

Device Marking	Device	Device Package	Reel Size	Tape width	Quantity (PCS)
60N04G	AP60N04G	PDFN5X6-8L	13 inch	-	5000

### ABSOLUTE MAXIMUM RATINGS ( $T_a=25^\circ\text{C}$ unless otherwise noted)

Parameter	Symbol	Value	Unit
Drain-Source Voltage	$V_{DS}$	40	V
Gate-Source Voltage	$V_{GS}$	$\pm 20$	V
Continuous Drain Current ( $T_a=25^\circ\text{C}$ )	$I_D$	40	A
Continuous Drain Current ( $T_a=100^\circ\text{C}$ )	$I_D$	26	A
Pulsed Drain Current <sup>(1)</sup>	$I_{DM}$	160	A
Singel Pulsed Avalanche Energy <sup>(2)</sup>	$E_{AS}$	101	mJ
Power Dissipation	$P_D$	56	W
Thermal Resistance from Junction to Case <sup>(4)</sup>	$R_{\theta JC}$	2.723	$^\circ\text{C}/\text{W}$
Junction Temperature	$T_J$	150	$^\circ\text{C}$
Storage Temperature	$T_{STG}$	-55~ +150	$^\circ\text{C}$

MOSFET ELECTRICAL CHARACTERISTICS( $T_a=25^{\circ}\text{C}$  unless otherwise noted)

Parameter	Symbol	Test Condition	Min	Type	Max	Unit
<b>Static Characteristics</b>						
Drain-source breakdown voltage	$V_{(BR)DSS}$	$V_{GS} = 0V, I_D = 250\mu A$	40	-	-	V
Zero gate voltage drain current	$I_{DSS}$	$V_{DS} = 40V, V_{GS} = 0V$	-	-	1	$\mu A$
Gate-body leakage current	$I_{GSS}$	$V_{GS} = \pm 20V, V_{DS} = 0V$	-	-	$\pm 100$	nA
Gate threshold voltage <sup>(3)</sup>	$V_{GS(th)}$	$V_{DS} = V_{GS}, I_D = 250\mu A$	1	1.6	2.5	V
Drain-source on-resistance <sup>(3)</sup>	$R_{DS(on)}$	$V_{GS} = 10V, I_D = 30A$	-	7.4	9.3	m $\Omega$
		$V_{GS} = 4.5V, I_D = 10A$	-	10.4	14.3	
<b>Dynamic characteristics</b>						
Input Capacitance	$C_{iss}$	$V_{DS} = 20V, V_{GS} = 0V, f = 1MHz$	-	1570	-	pF
Output Capacitance	$C_{oss}$		-	132	-	
Reverse Transfer Capacitance	$C_{rss}$		-	115	-	
<b>Switching characteristics</b>						
Turn-on delay time	$t_{d(on)}$	$V_{DD} = 20V, I_D = 25A, R_L = 4.7\Omega$ $V_{GS} = 10V, R_G = 1\Omega$	-	3.6	-	ns
Turn-on rise time	$t_r$		-	9.6	-	
Turn-off delay time	$t_{d(off)}$		-	24	-	
Turn-off fall time	$t_f$		-	9.6	-	
Total Gate Charge	$Q_g$	$V_{DS} = 20V, I_D = 25A,$ $V_{GS} = 10V$	-	32.5	-	nC
Gate-Source Charge	$Q_{gs}$		-	4.5	-	
Gate-Drain Charge	$Q_{gd}$		-	5.6	-	
<b>Source-Drain Diode characteristics</b>						
Diode Forward voltage <sup>(3)</sup>	$V_{DS}$	$V_{GS} = 0V, I_S = 10A$	-	-	1.2	V
Diode Forward current <sup>(4)</sup>	$I_S$		-	-	30	A
Body Diode Reverse Recovery Time	$t_{rr}$	$T_J = 25^{\circ}, I_F = 30A, di/dt = 100A/\mu s$		11		ns
Body Diode Reverse Recovery Charge	$Q_{rr}$	$T_J = 25^{\circ}, I_F = 30A, di/dt = 100A/\mu s$		6		nc

**Notes:**

1. Repetitive Rating: pulse width limited by maximum junction temperature
2. EAS Condition:  $T_J = 25^{\circ}\text{C}, V_{DD} = 20V, R_G = 25\Omega, L = 0.5\text{mH}$
3. Pulse Test: pulse width  $\leq 300\mu s$ , duty cycle  $\leq 2\%$
4. Surface Mounted on FR4 Board,  $t \leq 10\text{ sec}$

**Test Circuit & Waveform**

Gate Charge Test Circuit & Waveform

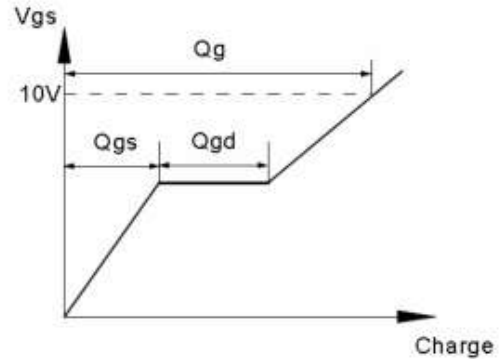
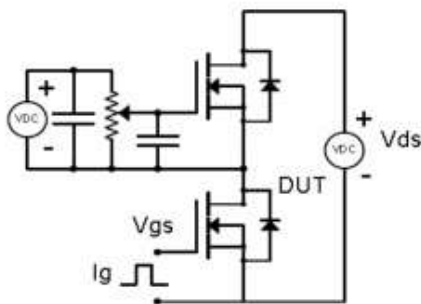

Resistive Switching Test Circuit & Waveforms

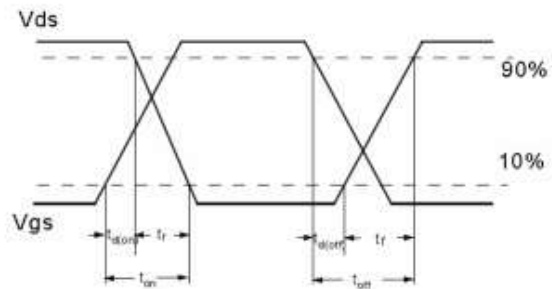
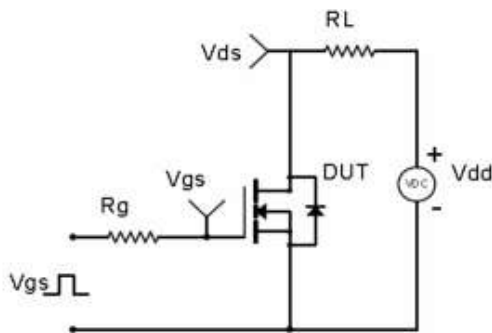

Unclamped Inductive Switching (UIS) Test Circuit & Waveforms

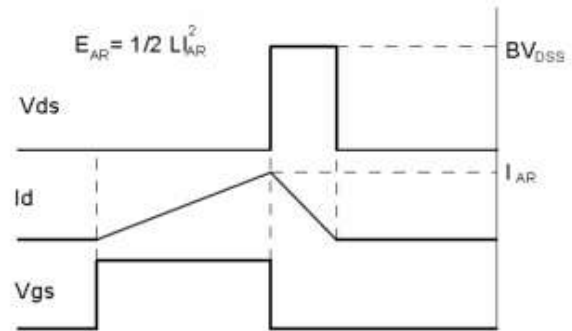
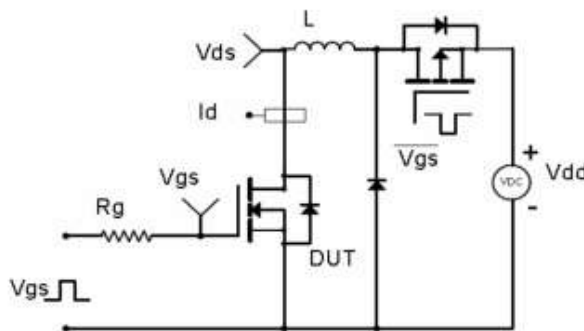

Diode Recovery Test Circuit & Waveforms

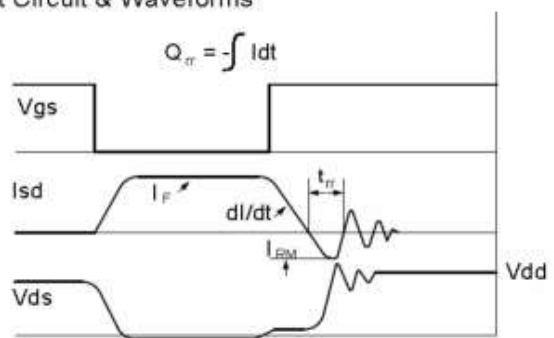
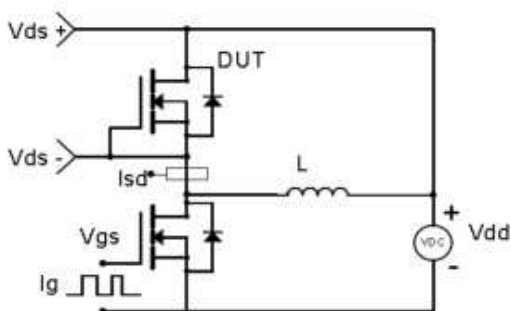

Fig.1 Power Dissipation Derating Curve

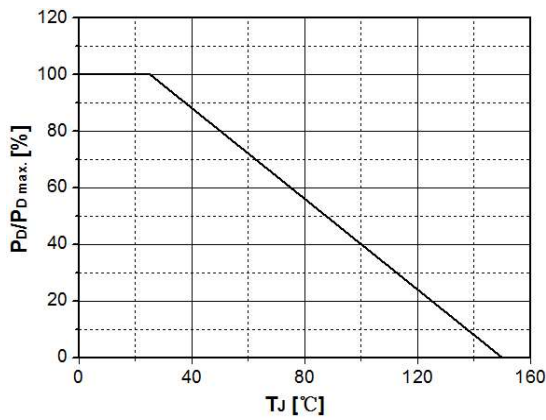

Fig.2 Avalanche Energy Derating Curve vs. Junction Temperature

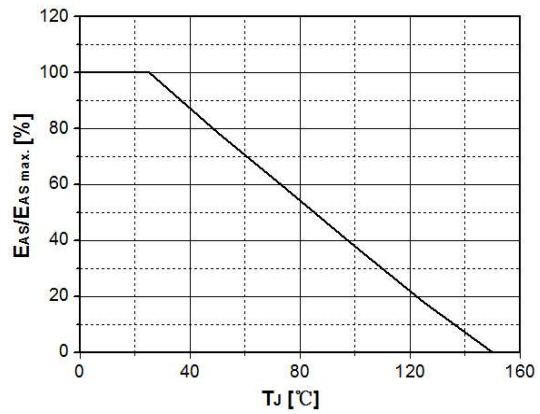

Fig.3 Typical Output Characteristics

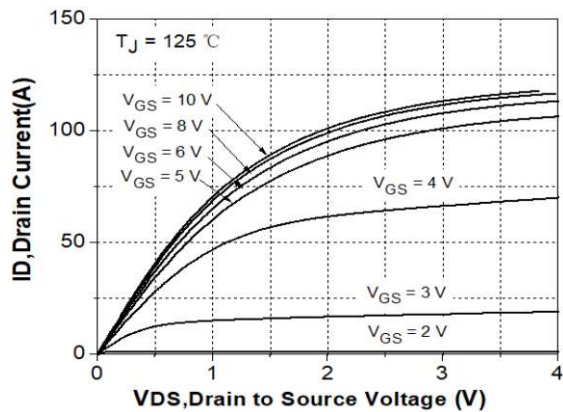

Fig. 4 Transconductance vs. Drain Current

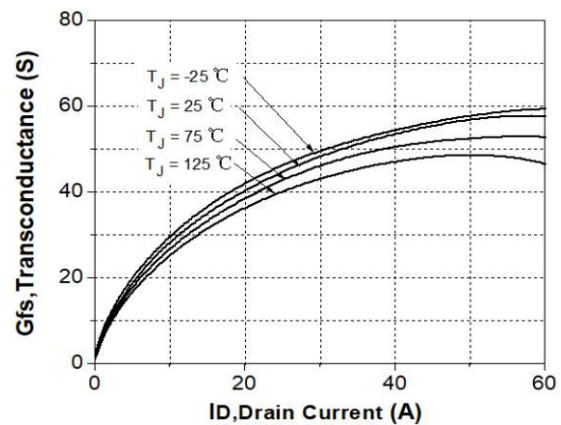

Fig.5 Typical Transfer Characteristics

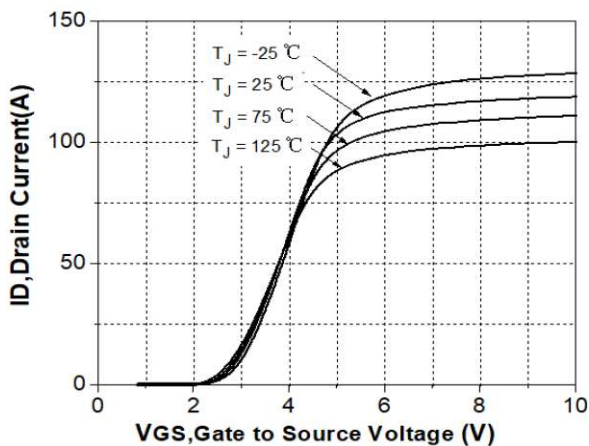

Fig. 6 State Resistance vs. Drain Current @-25°C

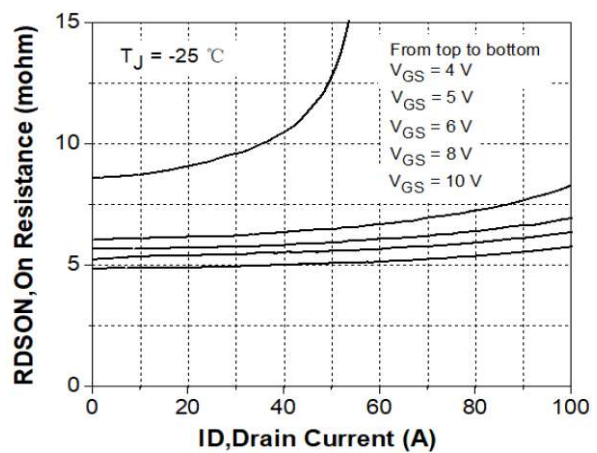

Fig.7 State Resistance vs. Drain Current @25°C

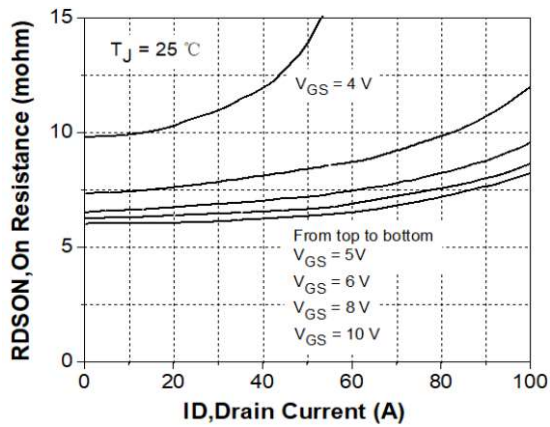

Fig. 8 State Resistance vs. Drain Current @125°C

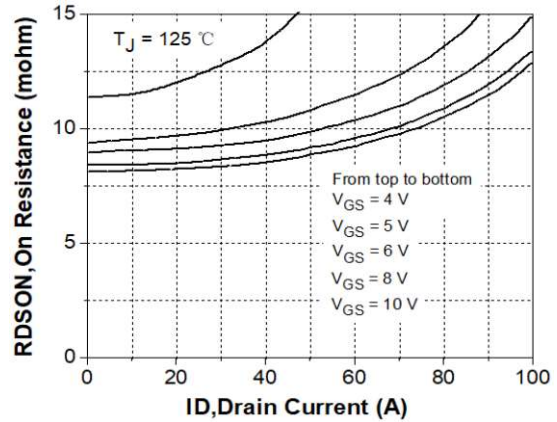

Fig.9 Typical Capacitance vs. Drain Source Voltage

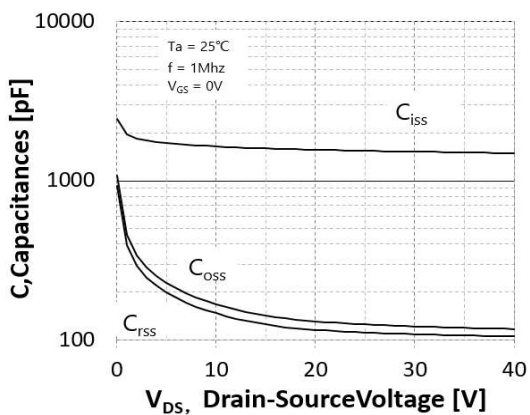

Fig.10 Dynamic Input Characteristics

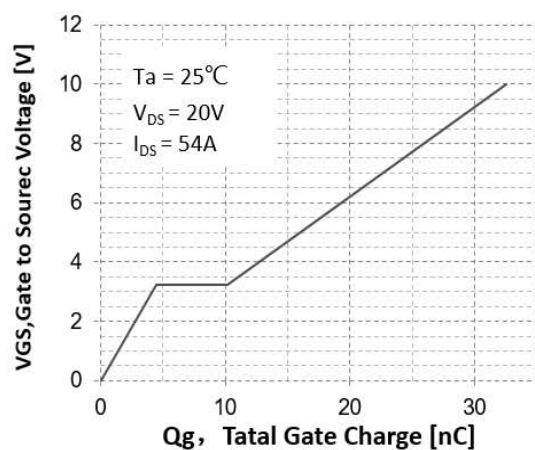

Fig.11 Breakdown Voltage vs. Junction Temperature

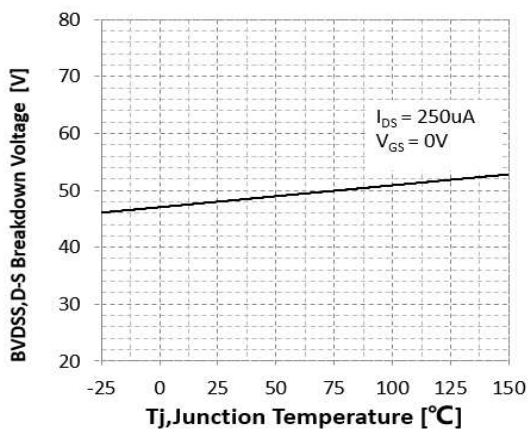

Fig. 12 Gate Threshold Voltage vs. Junction Temperature

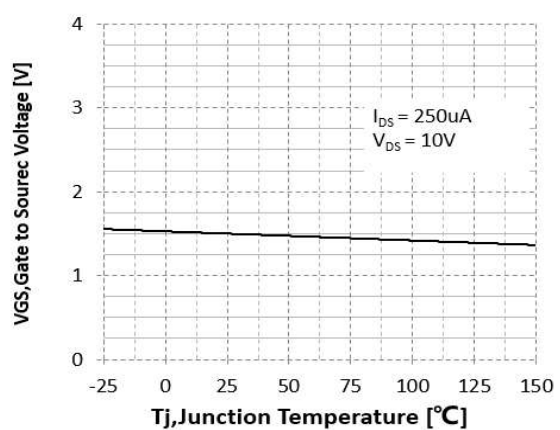

Fig.13 On-Resistance Variation vs. Junction Temperature

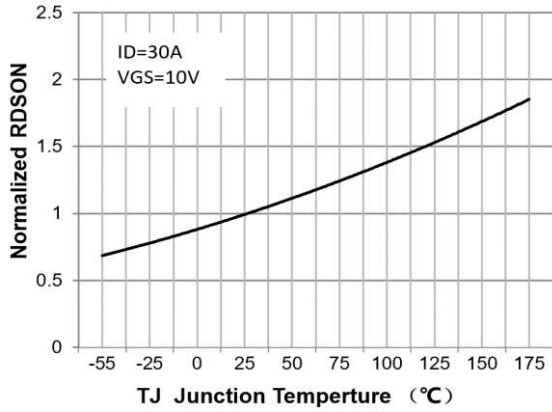

Fig.14 Maximum Drain Current vs. Case Temperature

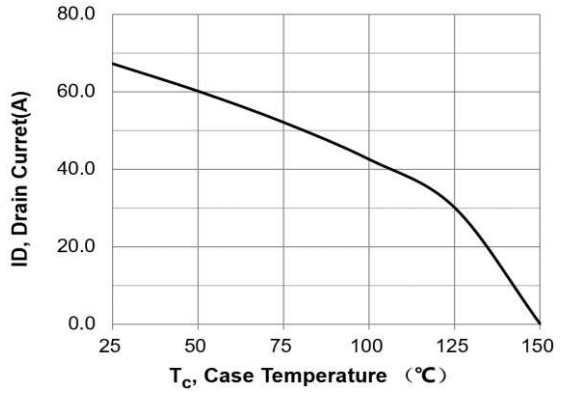

Fig.15 Body Diode Forward Voltage Vs Reverse Drain Current

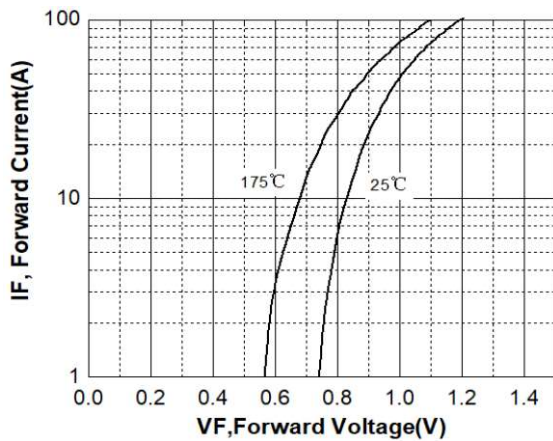

Fig.16 Safe Operating Area

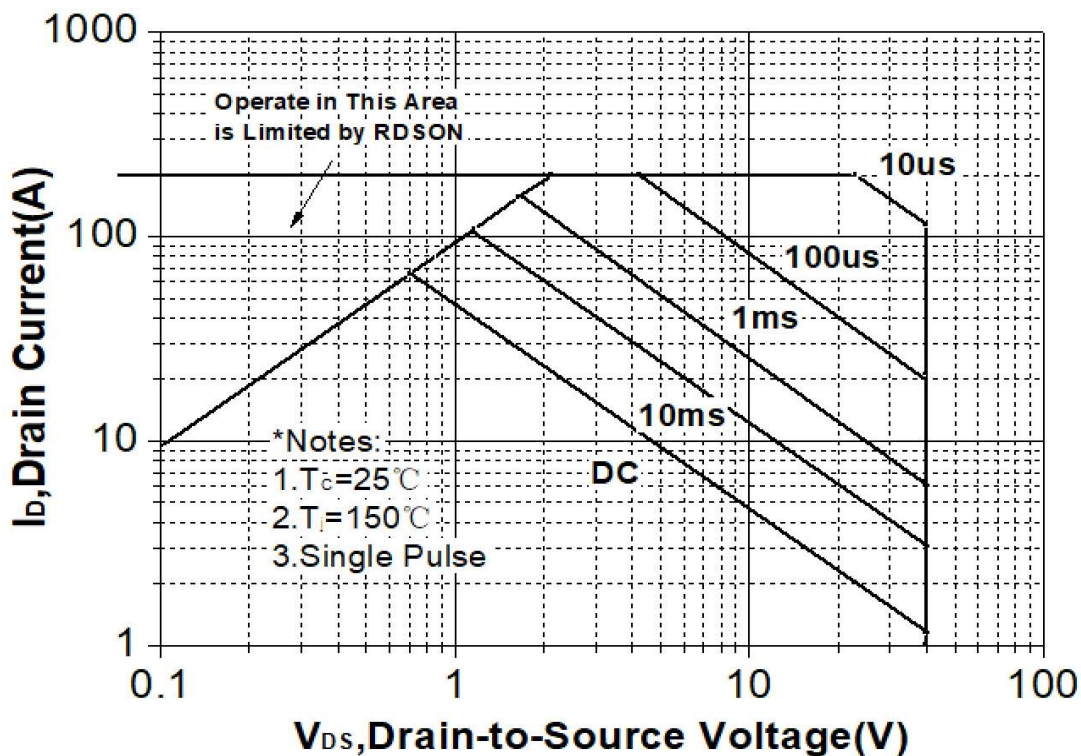
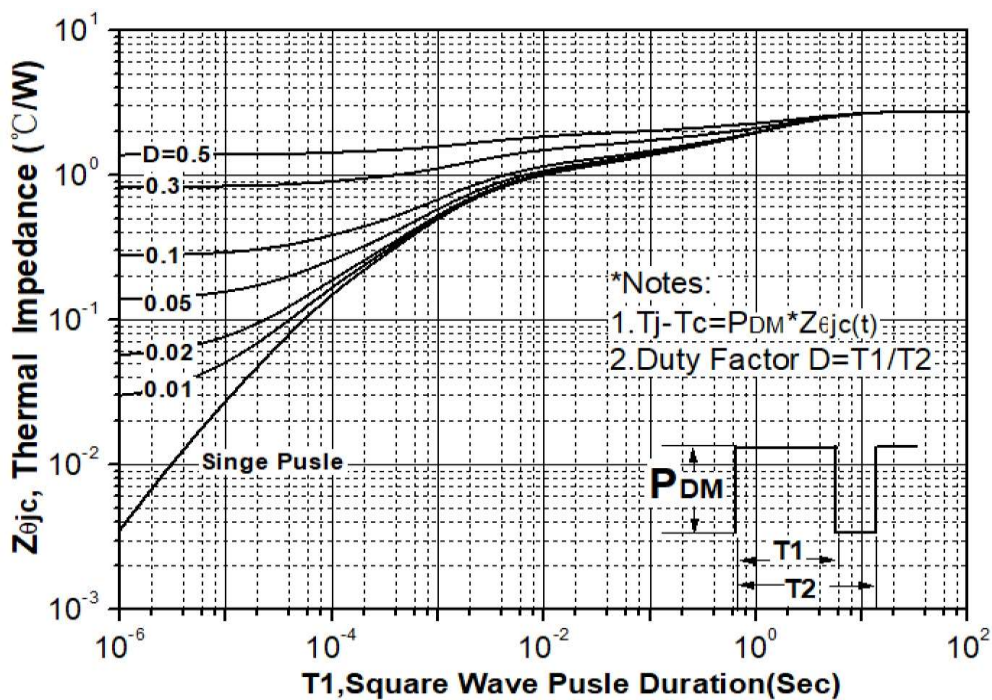
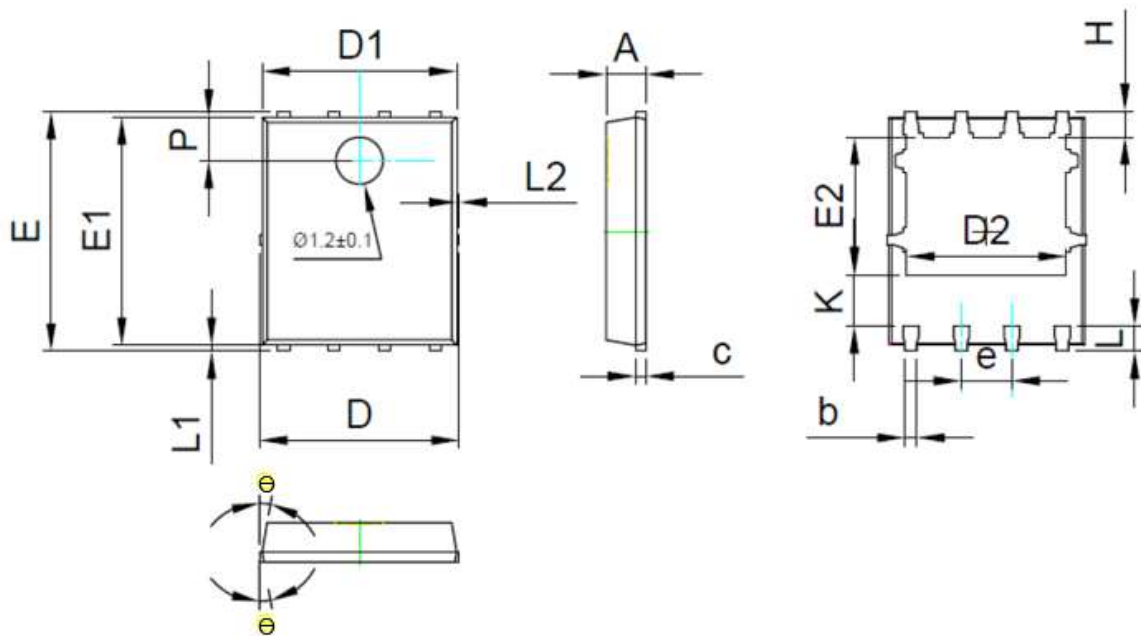

Fig. 17 Transient Thermal Response Curve



Package Dimensions : PDFN 5\*6 PACKAGE



**COMMON DIMENSIONS**  
( UNITS OF MEASURE = MILLIMETER )

SYMBOL	MIN	NOM	MAX
A	0.90	1.00	1.10
b	0.35	0.40	0.45
c	0.21	0.25	0.34
D	-	-	5.1
D1	4.85	4.90	4.95
D2	3.96	4.01	4.06
e	1.27 BSC		
E	5.95	6.00	6.05
E1	5.70	5.75	5.80
E2	3.425	3.475	3.525
H	0.60	0.65	0.70
K	1.29	-	-
L	0.60	0.65	0.70
L1	0.05	0.15	0.25
L2	-	-	0.12
θ	8°	10°	12°
P	1.05	1.10	1.15