

Feature

- 85V,120A
 $R_{DS(ON)} < 6m\Omega @ V_{GS}=10V$
- Advanced Trench Power MOSFET
- Provide Excellent $R_{DS(ON)}$ And Low Gate Charge

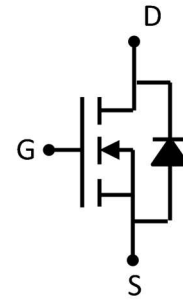

Schematic Diagram

Application

- DC/DC Converter
- Load Switch for Portable Devices
- Battery Switch
- Rectifier

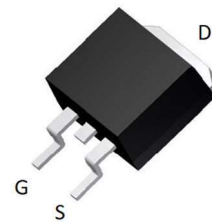

TO-263 top view

Package Marking and Ordering Information

Device Marking	Device	Device Package	Reel Size	Tape width	Quantity (PCS)
G060N85D	APG060N85D	TO-263		-	800

ABSOLUTE MAXIMUM RATINGS ($T_a=25^\circ\text{C}$ unless otherwise noted)

Parameter	Symbol	Value	Unit
Drain-Source Voltage	V_{DS}	85	V
Gate-Source Voltage	V_{GS}	± 20	V
Continuous Drain Current ($T_a = 25^\circ\text{C}$)	I_D	120	A
Continuous Drain Current ($T_a = 100^\circ\text{C}$)	I_D	85	A
Pulsed Drain Current ⁽¹⁾	I_{DM}	360	A
Singel Pulsed Avalanche Energy ⁽²⁾	E_{AS}	176	mJ
Power Dissipation	P_D	180	W
Thermal Resistance from Junction to Case	$R_{\theta JC}$	0.65	$^\circ\text{C}/\text{W}$
Junction Temperature	T_J	150	$^\circ\text{C}$
Storage Temperature	T_{STG}	-55~ +150	$^\circ\text{C}$

MOSFET ELECTRICAL CHARACTERISTICS(T_a=25°C unless otherwise noted)

Parameter	Symbol	Test Condition	Min	Type	Max	Unit
Static Characteristics						
Drain-source breakdown voltage	V _{(BR)DSS}	V _{GS} = 0V, I _D =250μA	85	-	-	V
Zero gate voltage drain current	I _{DSS}	V _{DS} =85V, V _{GS} = 0V	-	-	1	μA
Gate-body leakage current	I _{GSS}	V _{GS} =±20V, V _{DS} = 0V	-	-	±100	nA
Gate threshold voltage ⁽³⁾	V _{GS(th)}	V _{DS} =V _{GS} , I _D =250μA	2	3	4	V
Drain-source on-resistance ⁽³⁾	R _{DS(on)}	V _{GS} =10V, I _D =60A	-	5.5	6	mΩ
Forward tranconductance ⁽³⁾	g _{FS}	V _{DS} =10V, I _D =60A	-	90	-	S
Dynamic characteristics						
Input Capacitance	C _{iss}	V _{DS} =50V, V _{GS} =0V, f =1MHz	-	2448	-	pF
Output Capacitance	C _{oss}		-	628	-	
Reverse Transfer Capacitance	C _{rss}		-	15	-	
Switching characteristics						
Turn-on delay time	t _{d(on)}	V _{DD} =50V, I _D =60A, V _{GS} =10V, R _G =25Ω	-	15	-	ns
Turn-on rise time	t _r		-	29	-	
Turn-off delay time	t _{d(off)}		-	25	-	
Turn-off fall time	t _f		-	18	-	
Total Gate Charge	Q _g	V _{DS} =50V, I _D =60A, V _{GS} =10V	-	37	-	nC
Gate-Source Charge	Q _{gs}		-	2.2	-	
Gate-Drain Charge	Q _{gd}		-	25	-	
Source-Drain Diode characteristics						
Diode Forward voltage ⁽³⁾	V _{DS}	V _{GS} =0V, I _S =120A	-	-	1.2	V
Diode Forward current ⁽⁴⁾	I _S		-	-	120	A
Reverse recovery time	T _{rr}	I _S =60A, V _{GS} =0V, dI _F /dt=100A/us		50		ns
Reverse recovery charge	Q _{rr}	I _S =60A, V _{GS} =0V, dI _F /dt=100A/us		57		nC

Notes:

1. Repetitive Rating: pulse width limited by maximum junction temperature
2. EAS Condition: T_J=25°C, V_{DD}=10V, R_G=20 Ω, L=0.5mH, I_{AS}=28A
3. Pulse Test: pulse width≤300μs, duty cycle≤2%
4. Surface Mounted on FR4 Board, t≤10 sec

Test Circuit & Waveform

Gate Charge Test Circuit & Waveform

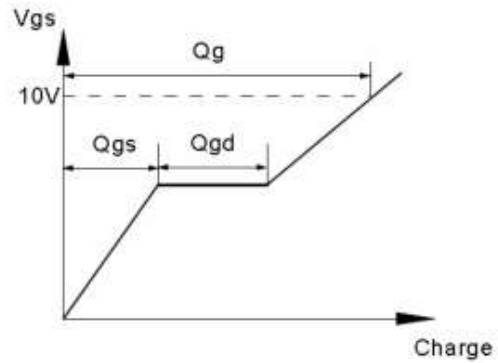
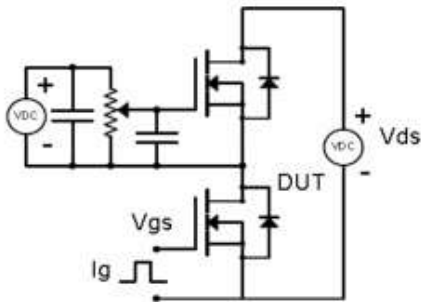

Resistive Switching Test Circuit & Waveforms

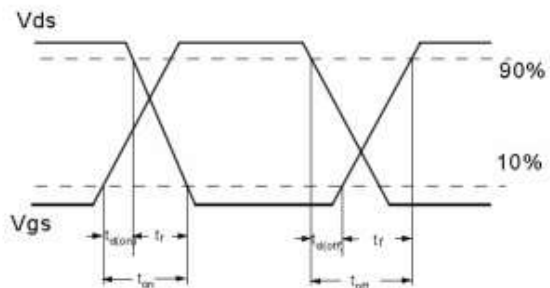
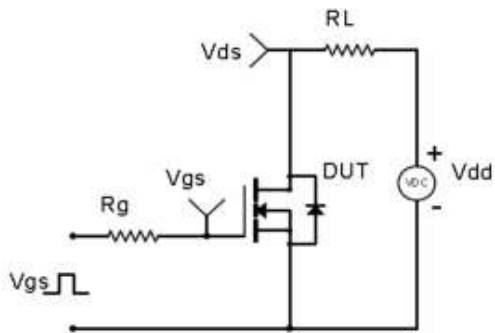

Unclamped Inductive Switching (UIS) Test Circuit & Waveforms

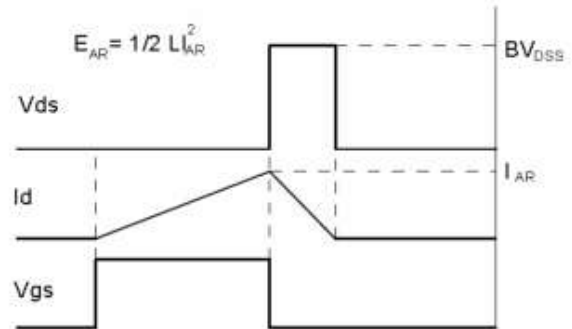
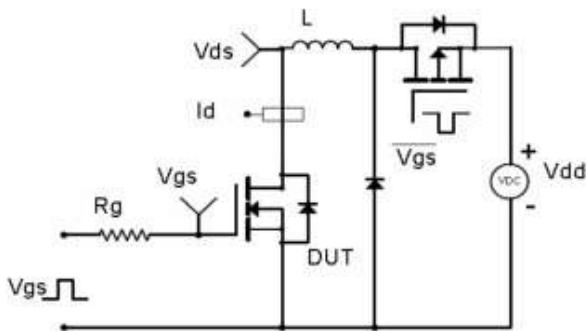

Diode Recovery Test Circuit & Waveforms

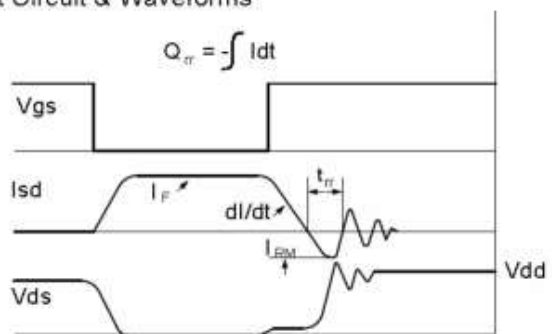
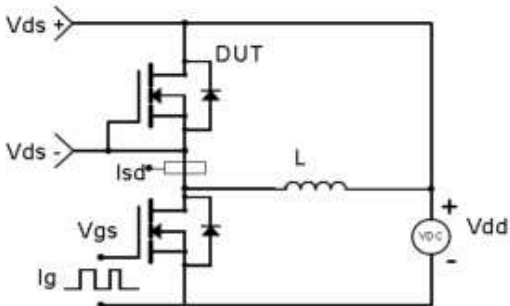

Typical Electronic and Thermal Characteristics

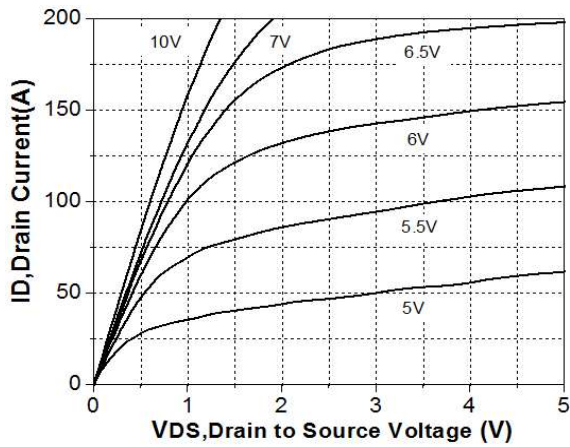

Figure 1. On-Region Characteristics

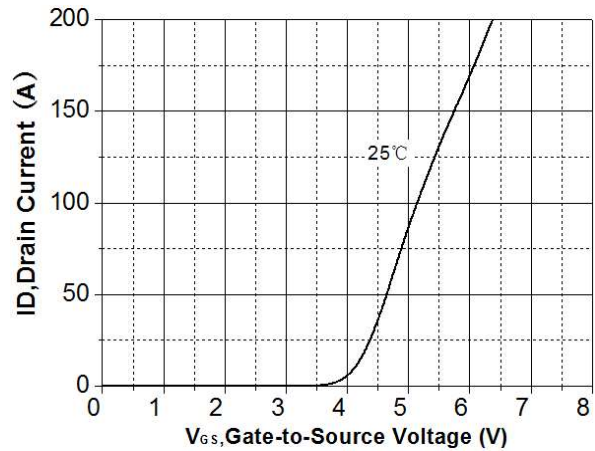

Figure 2. Transfer Characteristics

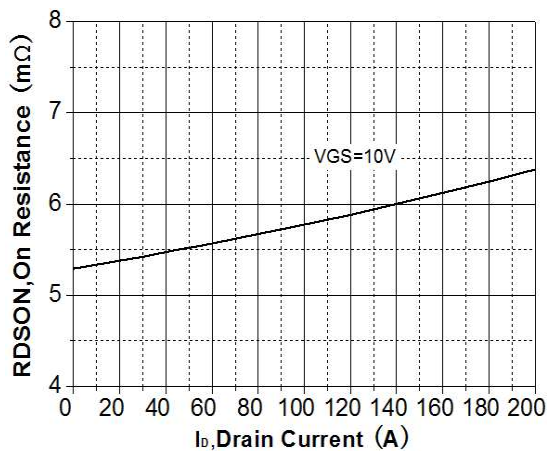

Figure 3. On-Resistance Variation vs Drain Current

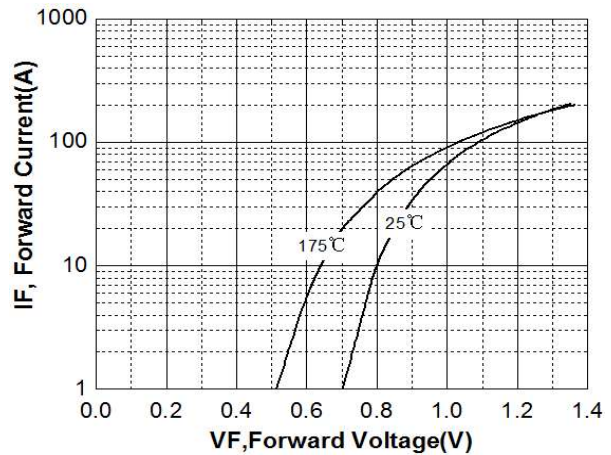

Figure 4. Body Diode Forward Voltage Vs Reverse Drain Current

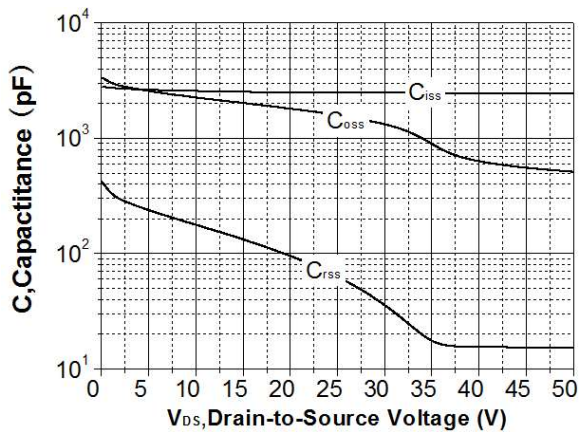

Figure 5. Capacitance Characteristics

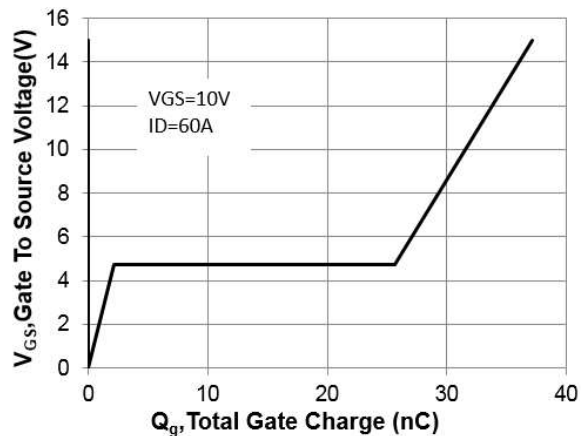

Figure 6. Gate Charge Characteristics

Typical Electronic and Thermal Characteristics

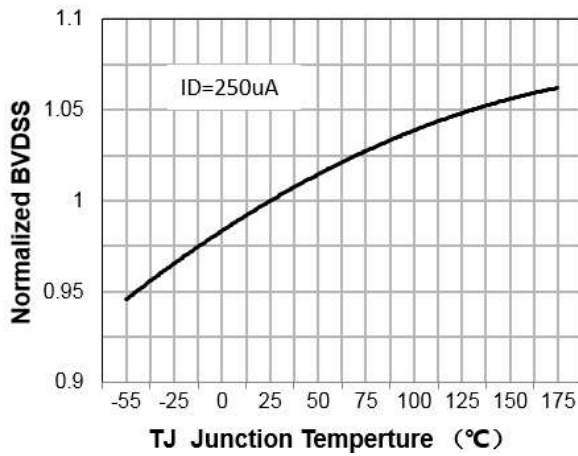

Figure 7. Breakdown Voltage Variation vs Temperature

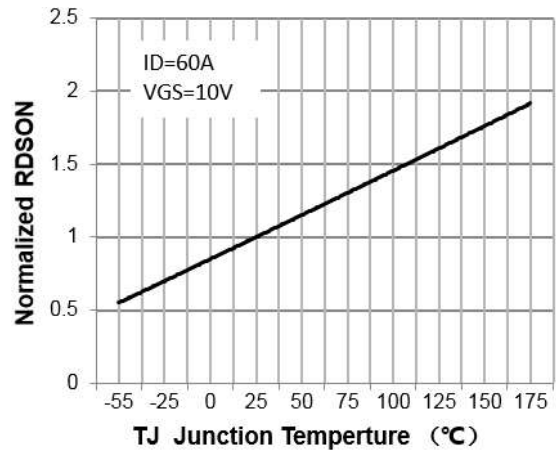

Figure 8. On-Resistance Variation vs Temperature

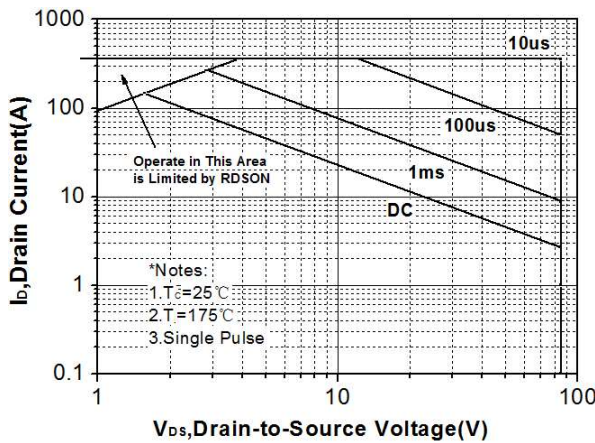

Figure 9. Maximum Safe Operating Area

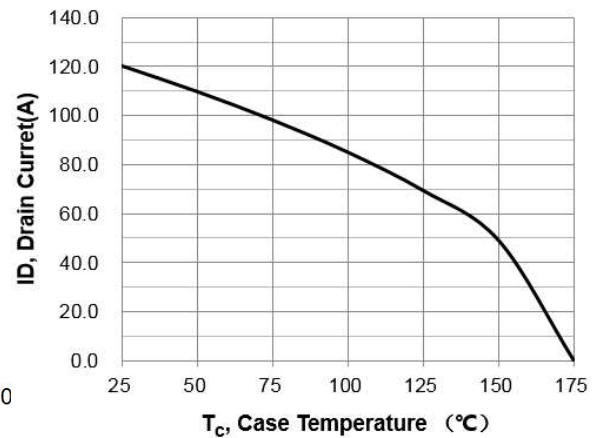

Figure 10. Maximum Drain Current vs Case Temperature

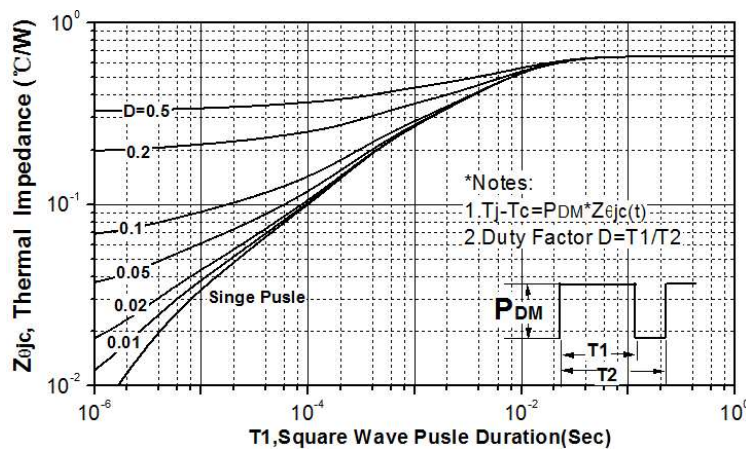
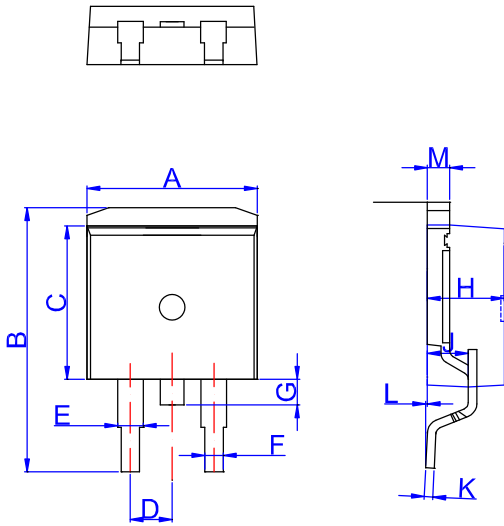

Figure 11. Transient Thermal Response Curve

TO-263 Package Information



TO-263

Ref.	Dimensions					
	Millimeters			Inches		
	Min.	Typ.	Max.	Min.	Typ.	Max.
A	9.90		10.20	0.390		0.402
B	14.70		15.80	0.579		0.622
C	9.4		9.6	0.37		0.378
D		2.54			0.100	
E	1.20		1.40	0.047		0.055
F	0.75		0.85	0.029		0.033
G			1.75			0.069
H	4.40		4.70	0.173		0.185
J	2.30		2.70	0.091		0.106
K	0.38		0.55	0.015		0.022
L	0	0.10	0.25	0	0.004	0.010
M	1.25		1.35	0.049		0.053