

AP7N65K

N-Channel Enhancement Mosfet

Features

- 650V,7A
 $R_{DS(ON)} < 1.35 \Omega @ V_{GS}=10V$ TYP:1.1 Ω
- Fast switching
- 100% avalanche tested
- Improved dv/dt capability

Applications

- Switch Mode Power Supply (SMPS)
- Uninterruptible Power Supply (UPS)
- Power Factor Correction (PFC) PWM applications

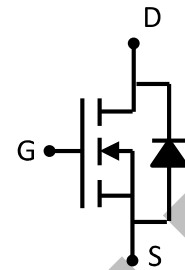

Schematic diagram



Marking and pin assignment

Package Marking and Ordering Information

Device Marking	Device	Device Package	Reel Size	Tape width	Quantity (PCS)
7N65K	AP7N65K	TO-252	-	-	2500

ABSOLUTE MAXIMUM RATINGS ($T_a=25^\circ\text{C}$ unless otherwise noted)

Parameter	Symbol	Value	Unit
Drain-Source Voltage	V_{DS}	650	V
Gate-Source Voltage	V_{GS}	± 30	V
Continuous Drain Current ($T_a=25^\circ\text{C}$)	I_D	7	A
Avalanche Current ⁽¹⁾	I_{AS}	5.76	A
Pulsed Drain Current ⁽¹⁾	I_{DM}	28	A
Single Pulsed Avalanche Energy ⁽²⁾	E_{AS}	165	mJ
Repetitive Avalanche Energy ⁽¹⁾	E_{AR}	100	mJ
Power Dissipation	P_D	97	W
Thermal Resistance from Junction to Case	$R_{\theta JC}$	1.29	$^\circ\text{C}/\text{W}$
Junction Temperature	T_J	150	$^\circ\text{C}$
Storage Temperature	T_{STG}	-55~ +150	$^\circ\text{C}$

MOSFET ELECTRICAL CHARACTERISTICS($T_a=25^{\circ}\text{C}$ unless otherwise noted)

Parameter	Symbol	Test Condition	Min	Type	Max	Unit
Static Characteristics						
Drain-source breakdown voltage	$V_{(BR)DSS}$	$V_{GS} = 0V, I_D = 250\mu A$	650	-	-	V
Zero gate voltage drain current	I_{DSS}	$V_{DS} = 650V, V_{GS} = 0V, T_J = 25^{\circ}\text{C}$	-	-	1	μA
Gate-body leakage current	I_{GSS}	$V_{GS} = \pm 30V, V_{DS} = 0V$	-	-	± 100	nA
Gate threshold voltage	$V_{GS(th)}$	$V_{DS} = V_{GS}, I_D = 250\mu A$	3.0	-	4.0	V
Drain-source on-resistance ⁽³⁾	$R_{DS(on)}$	$V_{GS} = 10V, I_D = 3.5A$	-	1.1	1.35	Ω
Dynamic characteristics						
Input Capacitance	C_{iss}	$V_{DS} = 25V, V_{GS} = 0V, f = 1.0\text{MHz}$	-	891	-	pF
Output Capacitance	C_{oss}		-	87	-	
Reverse Transfer Capacitance	C_{rss}		-	10	-	
Switching characteristics						
Turn-on delay time	$t_{d(on)}$	$V_{DD} = 325V, I_D = 7A, R_G = 25\Omega$	-	39	-	ns
Turn-on rise time	t_r		-	23	-	
Turn-off delay time	$t_{d(off)}$		-	137	-	
Turn-off fall time	t_f		-	60	-	
Total Gate Charge	Q_g	$V_{DS} = 520V, I_D = 7A, V_{GS} = 10V$	-	32	-	nC
Gate-Source Charge	Q_{gs}		-	4.6	-	
Gate-Drain Charge	Q_{gd}		-	14	-	
Source-Drain Diode characteristics						
Diode Forward voltage	V_{SD}	$T_J = 25^{\circ}\text{C}, V_{GS} = 0V, I_S = 3.5A$	-	-	1.4	V
Diode Forward current	I_S	$T_C = 25^{\circ}\text{C}$	-	-	7	A
Body Diode Reverse Recovery Time	t_{rr}	$T_J = 25^{\circ}\text{C}, I_F = 7A, di/dt = 100A/\mu s$		575		ns
Body Diode Reverse Recovery Charge	Q_{rr}	$T_J = 25^{\circ}\text{C}, I_F = 7A, di/dt = 100A/\mu s$		1.9		uc

Notes:

1. Repetitive Rating: pulse width limited by maximum junction temperature
2. EAS Condition: $T_J = 25^{\circ}\text{C}, V_{DD} = 50V, R_G = 25\Omega, L = 10\text{mH}$
3. Pulse Test: pulse width $\leq 300\mu s$, duty cycle $\leq 1\%$

Typical Characteristics $T_J = 25^\circ\text{C}$, unless otherwise noted

Figure 1. Output Characteristics ($T_J = 25^\circ\text{C}$)

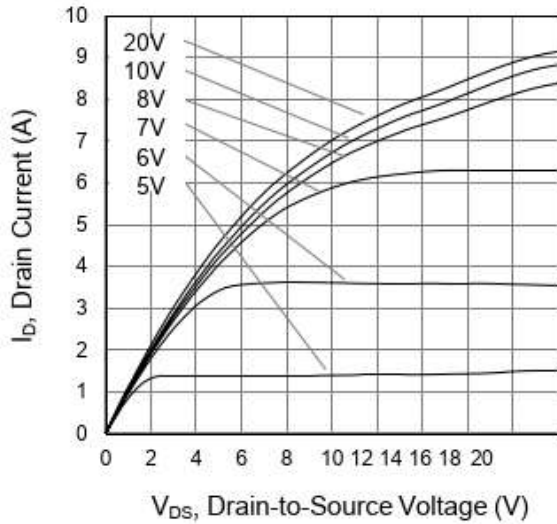

Figure 2. Body Diode Forward Voltage

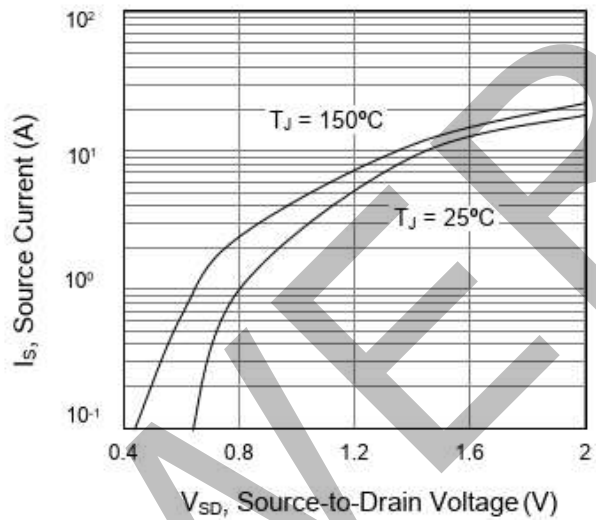

Figure 3. Drain Current vs. Temperature

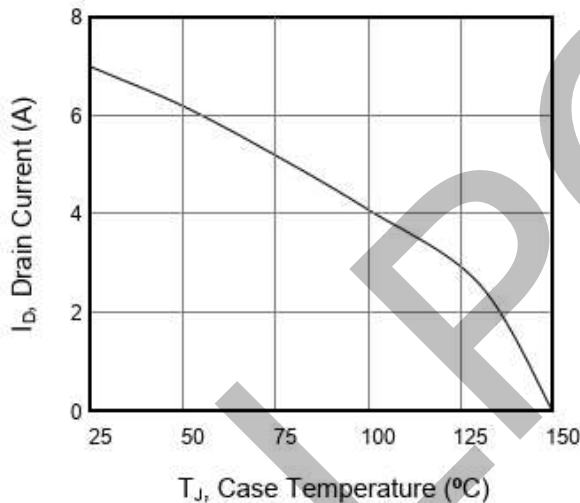

Figure 4. BV_{DSS} Variation vs. Temperature

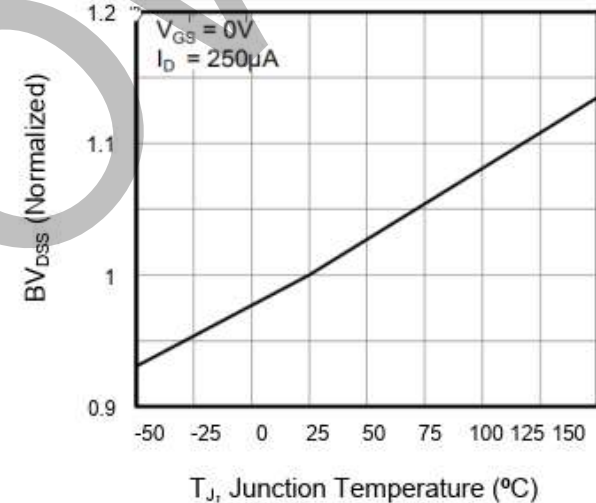

Figure 5. Transfer Characteristics

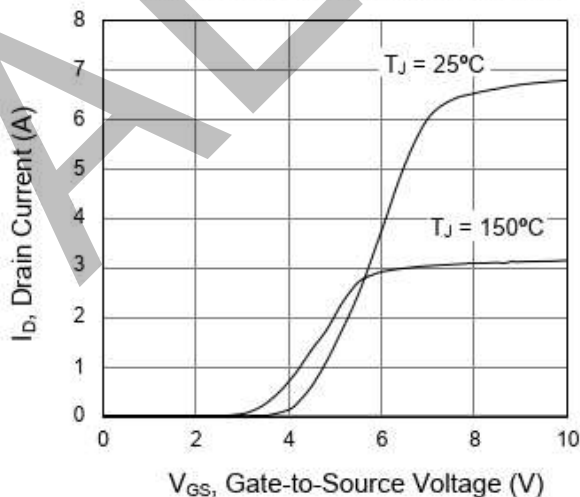
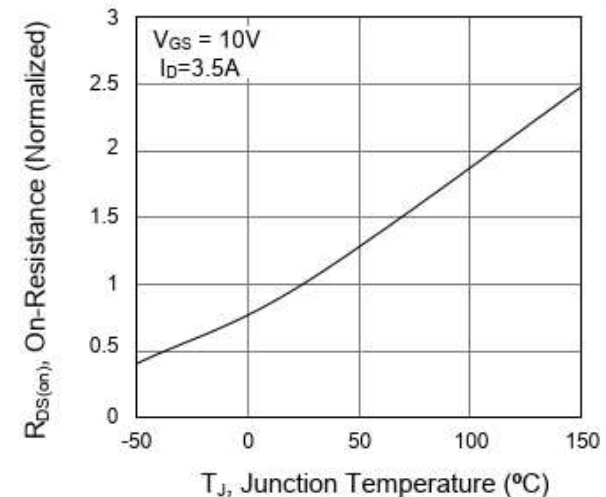

Figure 6. On-Resistance vs. Temperature



Typical Characteristics $T_J = 25^\circ\text{C}$, unless otherwise noted

Figure 7. Capacitance

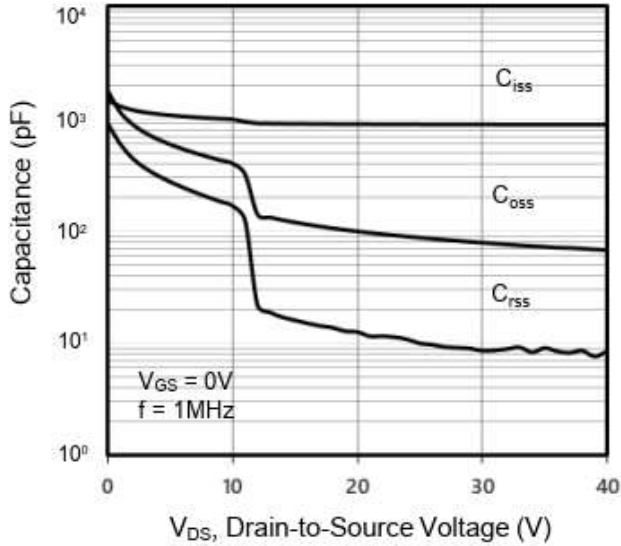

Figure 8. Gate Charge

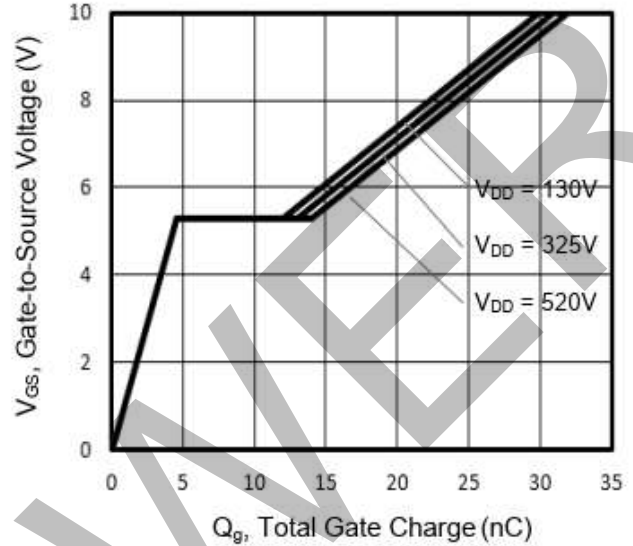

Figure 9. Transient Thermal Impedance TO-220, TO-251, TO-252

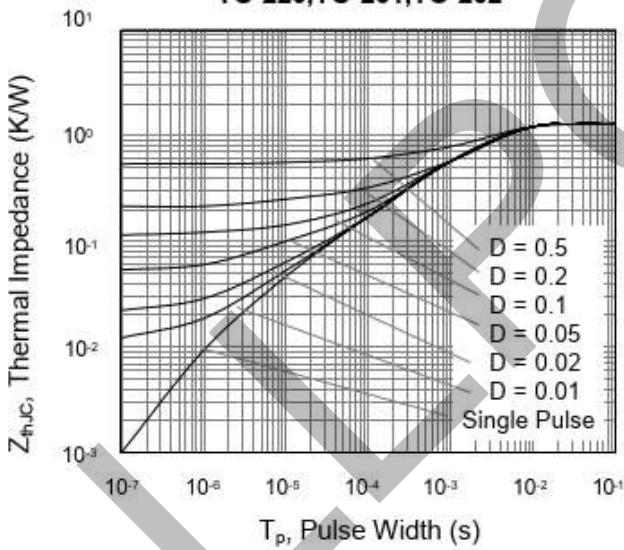
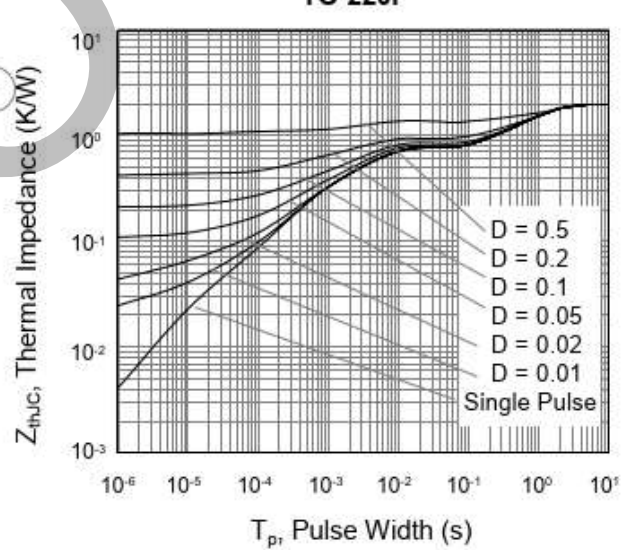
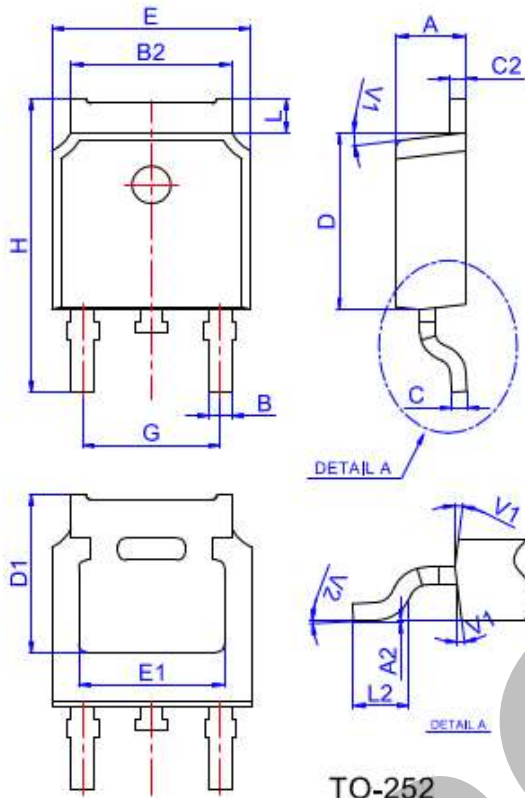

Figure 10. Transient Thermal Impedance TO-220F



TO-252 Package Information



Ref.	Dimensions					
	Millimeters			Inches		
	Min.	Typ.	Max.	Min.	Typ.	Max.
A	2.10		2.50	0.083		0.098
A2	0		0.10	0		0.004
B	0.66		0.86	0.026		0.034
B2	5.18		5.48	0.202		0.216
C	0.40		0.60	0.016		0.024
C2	0.44		0.58	0.017		0.023
D	5.90		6.30	0.232		0.248
D1	5.30REF			0.209REF		
E	6.40		6.80	0.252		0.268
E1	4.63			0.182		
G	4.47		4.67	0.176		0.184
H	9.50		10.70	0.374		0.421
L	1.09		1.21	0.043		0.048
L2	1.35		1.65	0.053		0.065
V1		7°			7°	
V2		0°	6°	0°	7°	6°

TO-252

Reel Specification-TO-252

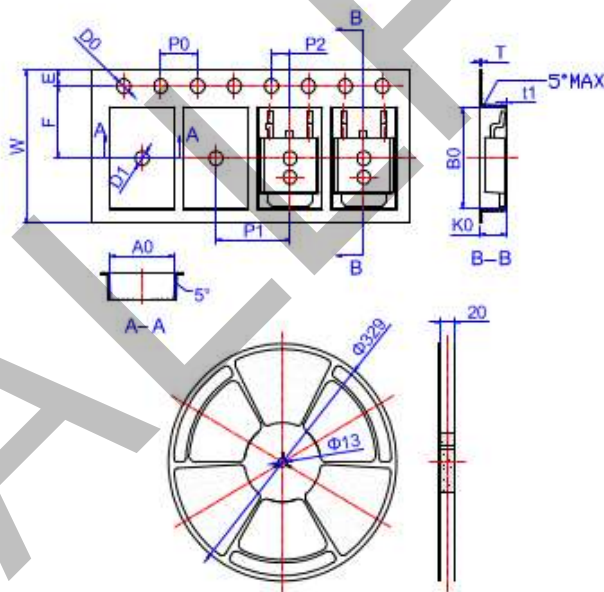

Ref.	Dimensions					
	Millimeters			Inches		
	Min.	Typ.	Max.	Min.	Typ.	Max.
W	15.90	16.00	16.10	0.626	0.630	0.634
E	1.65	1.75	1.85	0.065	0.069	0.073
F	7.40	7.50	7.60	0.291	0.295	0.299
D0	1.40	1.50	1.60	0.055	0.059	0.063
D1	1.40	1.50	1.60	0.055	0.059	0.063
P0	3.90	4.00	4.10	0.154	0.157	0.161
P1	7.90	8.00	8.10	0.311	0.315	0.319
P2	1.90	2.00	2.10	0.075	0.079	0.083
A0	6.85	6.90	7.00	0.270	0.271	0.276
B0	10.45	10.50	10.60	0.411	0.413	0.417
K0	2.68	2.78	2.88	0.105	0.109	0.113
T	0.24		0.27	0.009		0.011
t1	0.10			0.004		
10P0	39.80	40.00	40.20	1.567	1.575	1.583