

AP12N65D

N-Channel Enhancement Mosfet

AIIPOWER

DATA SHEET

Features

- 650V,12A
 $R_{DS(ON)} < 800m\Omega @ V_{GS}=10V$ TYP:605m Ω
- Fast switching
- 100% avalanche tested
- Improved dv/dt capability

Applications

- Switch Mode Power Supply (SMPS)
- Uninterruptible Power Supply (UPS)
- Power Factor Correction (PFC)
- LED lighting power

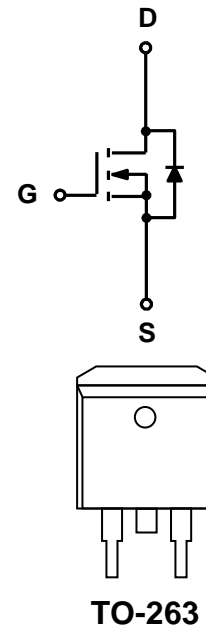

Package Marking and Ordering Information

Device Marking	Device	Device Package	Reel Size	Tape width	Quantity (PCS)
12N65D	AP12N65D	TO-263	-	-	800

ABSOLUTE MAXIMUM RATINGS ($T_a=25^\circ\text{C}$ unless otherwise noted)

Parameter	Symbol	Value	Unit
Drain-Source Voltage	V_{DS}	650	V
Gate-Source Voltage	V_{GS}	± 30	V
Continuous Drain Current ($T_a = 25^\circ\text{C}$)	I_D	12	A
Avalanche Current ⁽¹⁾	I_{AS}	48	A
Pulsed Drain Current ⁽¹⁾	I_{DM}	48	A
Single Pulsed Avalanche Energy ⁽²⁾	E_{AS}	311	mJ
Power Dissipation	P_D	225	W
Thermal Resistance from Junction to Case	$R_{\theta JC}$	0.56	$^\circ\text{C/W}$
Thermal Resistance from Junction to Ambient	$R_{\theta JA}$	62.5	$^\circ\text{C/W}$
Junction Temperature	T_J	150	$^\circ\text{C}$
Storage Temperature	T_{STG}	-55~ +150	$^\circ\text{C}$

MOSFET ELECTRICAL CHARACTERISTICS($T_a=25^\circ\text{C}$ unless otherwise noted)

Parameter	Symbol	Test Condition	Min	Type	Max	Unit
Static Characteristics						
Drain-source breakdown voltage	$V_{(BR)DSS}$	$V_{GS} = 0V, I_D = 250\mu A$	650	-	-	V
Zero gate voltage drain current	I_{DSS}	$V_{DS} = 650V, V_{GS} = 0V, T_J = 25^\circ\text{C}$	-	-	1	μA
Gate-body leakage current	I_{GSS}	$V_{GS} = \pm 30V, V_{DS} = 0V$	-	-	± 100	nA
Gate threshold voltage	$V_{GS(th)}$	$V_{DS} = V_{GS}, I_D = 250\mu A$	2.0	3.0	4.0	V
Drain-source on-resistance ⁽³⁾	$R_{DS(on)}$	$V_{GS} = 10V, I_D = 3.0A$	-	573	790	$m\Omega$
		$V_{GS} = 10V, I_D = 6.0A$		605	800	$m\Omega$
Dynamic characteristics						
Input Capacitance	C_{iss}	$V_{DS} = 25V, V_{GS} = 0V, f = 1.0MHz$	-	2100	-	pF
Output Capacitance	C_{oss}		-	162.6	-	
Reverse Transfer Capacitance	C_{rss}		-	7.0	-	
Switching characteristics						
Turn-on delay time	$t_{d(on)}$	$V_{DD} = 325V, I_D = 12A, R_G = 25\Omega$	-	27.6	-	ns
Turn-on rise time	t_r		-	52.6	-	
Turn-off delay time	$t_{d(off)}$		-	75.2	-	
Turn-off fall time	t_f		-	42.5	-	
Total Gate Charge	Q_g	$V_{DS} = 520V, I_D = 12A,$ $V_{GS} = 10V$	-	37	-	nC
Gate-Source Charge	Q_{gs}		-	7.4	-	
Gate-Drain Charge	Q_{gd}		-	18	-	
Source-Drain Diode characteristics						
Diode Forward voltage	V_{SD}	$T_J = 25^\circ\text{C}, V_{GS} = 0V, I_S = 12A$	-	-	1.4	V
Diode Forward current	I_S	$T_C = 25^\circ\text{C}$	-	-	12	A
Body Diode Reverse Recovery Time	t_{rr}	$T_J = 25^\circ\text{C}, I_F = 12A, di/dt = 100A/\mu s$		566		ns
Body Diode Reverse Recovery Charge	Q_{rr}	$T_J = 25^\circ\text{C}, I_F = 12A, di/dt = 100A/\mu s$		58		uc

Notes:

1. Pulse width limited by maximum junction temperature
2. $L=20mH, V_{DD}=100V, V_G=10V, R_G=25\Omega$, starting $T_J=25^\circ\text{C}$
3. Pulse Test: Pulse width $\leq 300\mu s$, Duty cycle $\leq 2\%$
4. Essentially independent of operating temperature

Typical Performance Characteristics

Figure 1. On-Region Characteristics

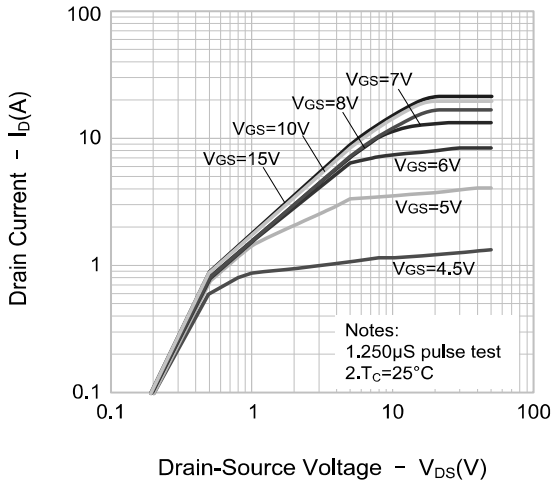

Figure 2. Transfer Characteristics

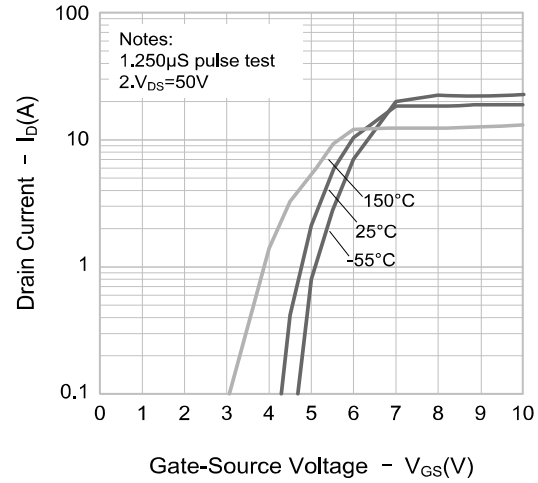

Figure 3. On-resistance vs. Drain Current

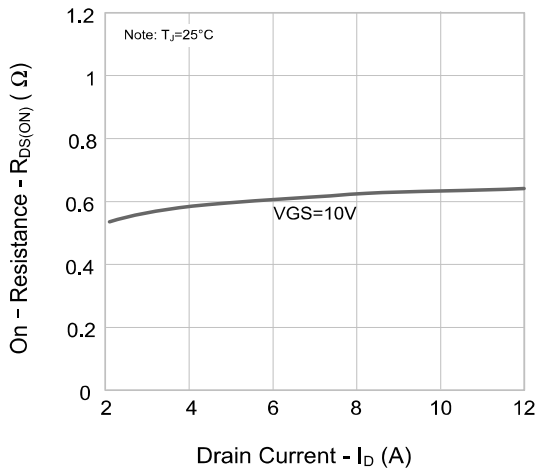

Figure 4. Body Diode Forward Voltage Variation vs. Source Current and Temperature

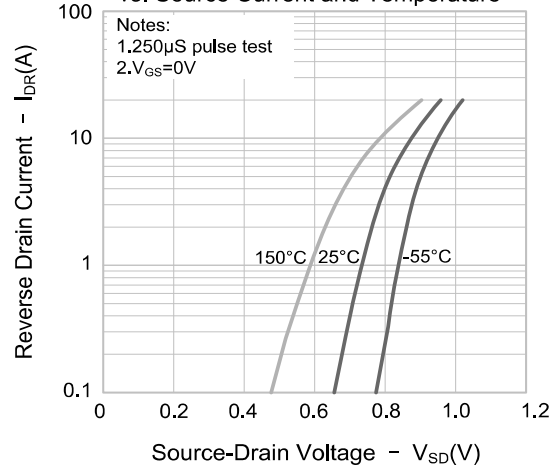

Figure 5. Capacitance Characteristics

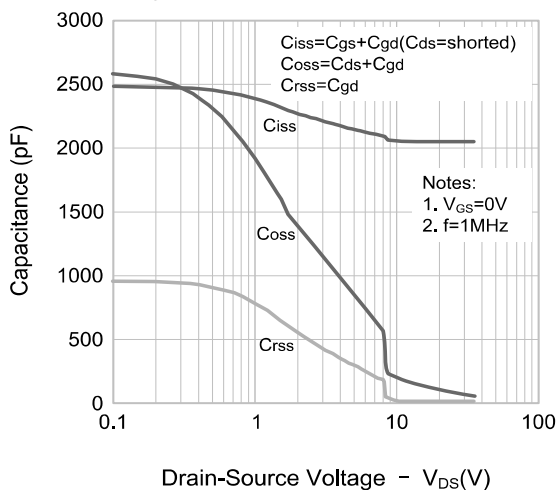
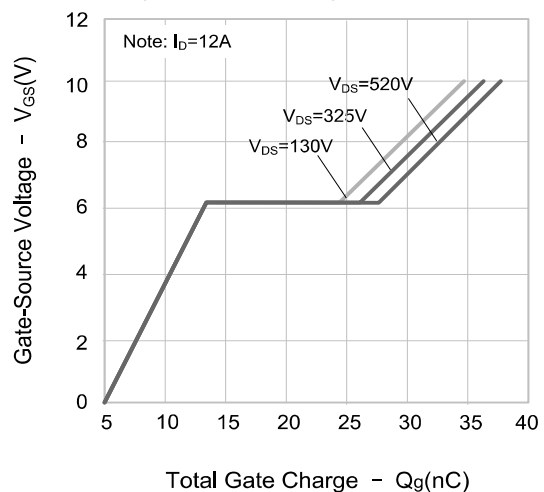

Figure 6. Gate Charge Characteristics



Typical Performance Characteristics

Figure 7. Breakdown Voltage Variation vs. Temperature

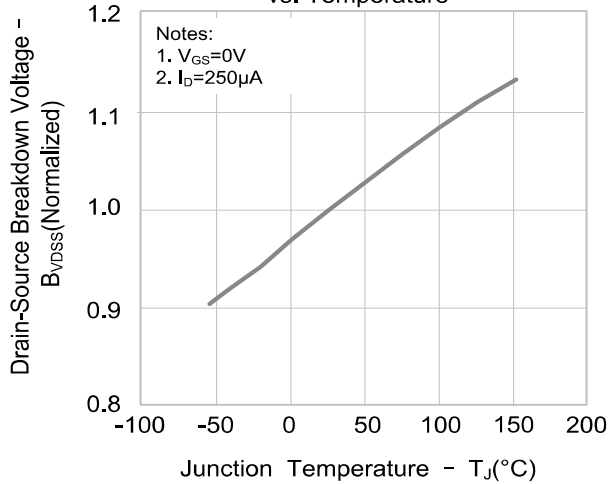

Figure 8. On-resistance vs. Temperature

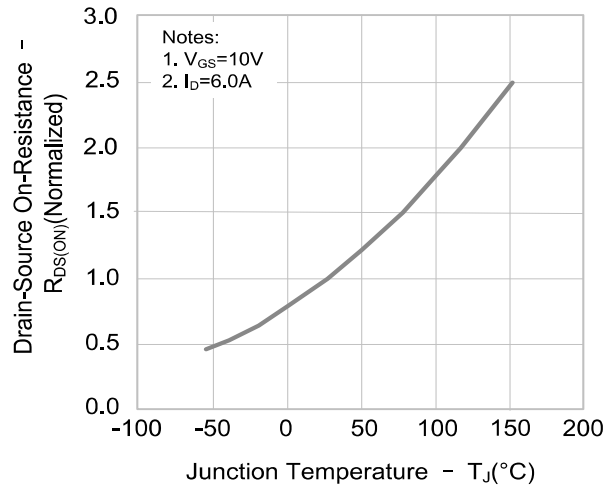
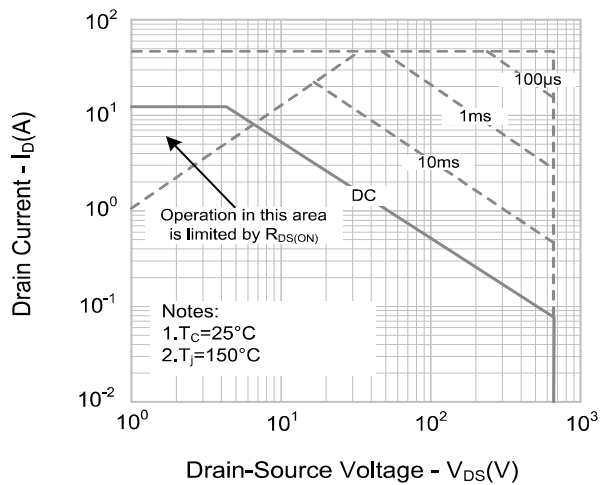
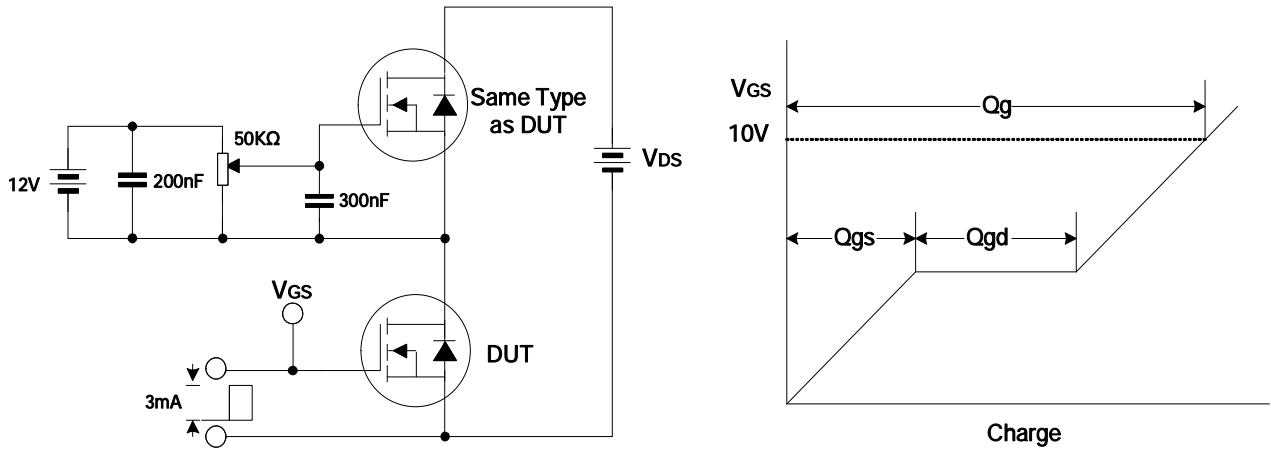

Figure 9. Max. Safe Operating Area



TYPICAL TEST CIRCUIT

Gate Charge Test Circuit & Waveform



Resistive Switching Test Circuit & Waveform

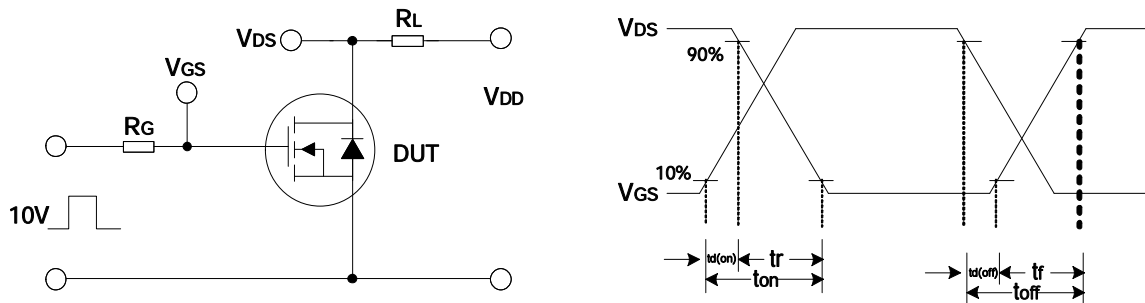

Unclamped Inductive Switching Test Circuit & Waveform

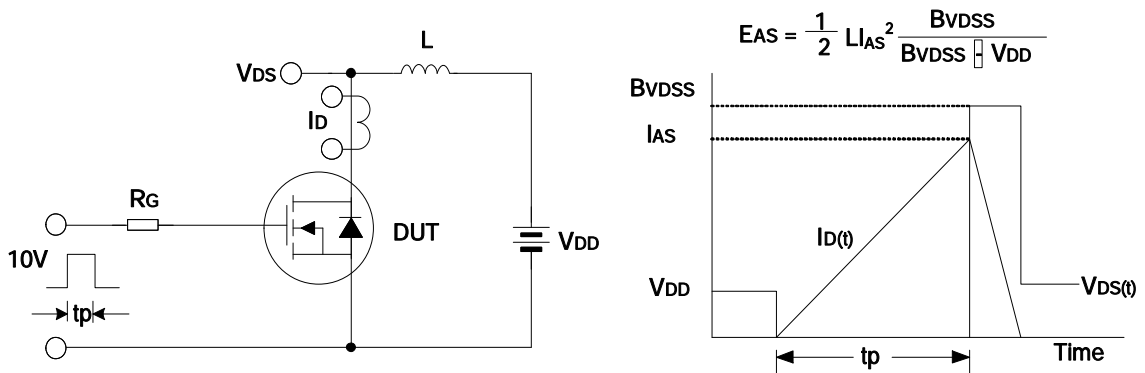

Package Dimensions of TO-263

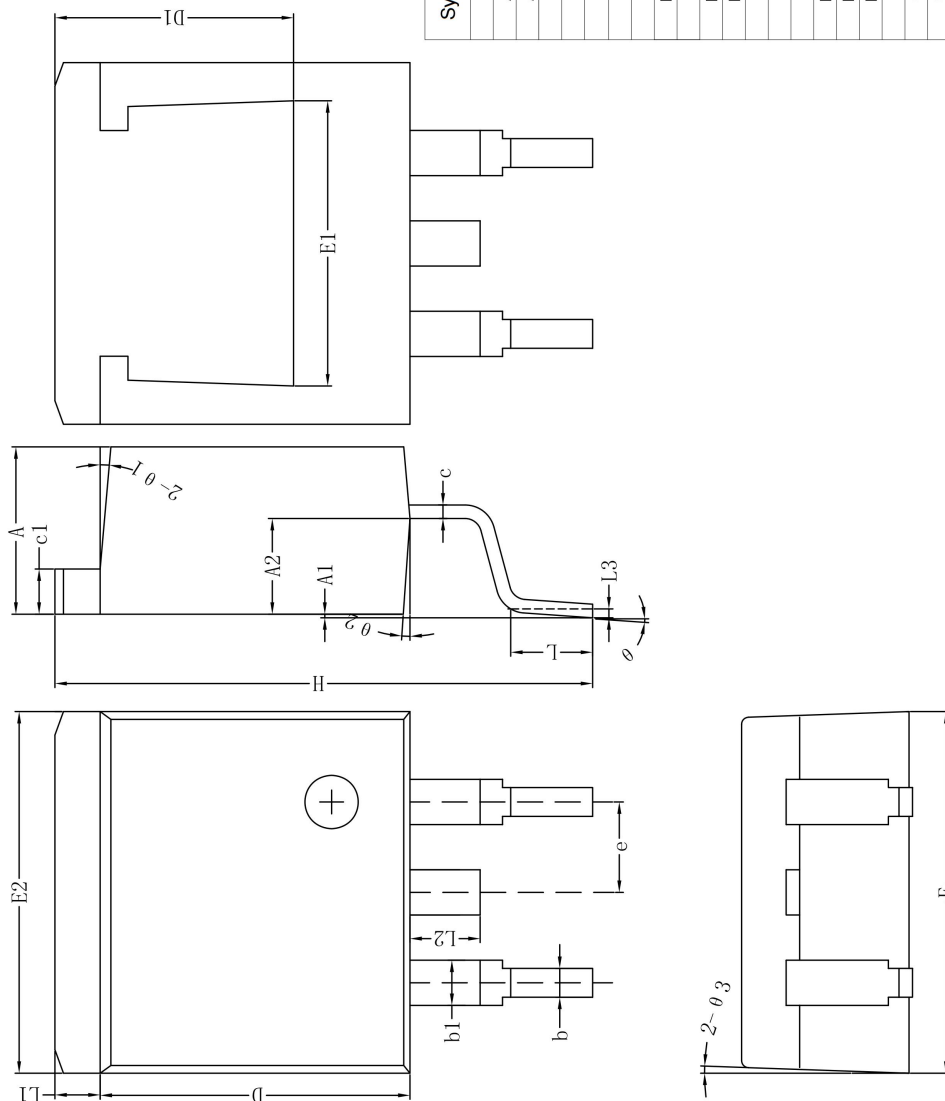

Symbol	Size /mm		
	MIN	NOM	MAX
A	4.55	4.70	4.85
A1	0	0.10	0.25
A2	2.59	2.69	2.89
b	0.71	0.81	0.96
b1		1.27	
c	0.36	0.38	0.61
c1	1.17	1.27	1.37
D	8.55	8.70	8.85
D1	6.70		7.70
E	10.01	10.16	10.31
E1	7.2		8.1
E2	9.98	10.08	10.18
e		2.54	
H	14.7	15.1	15.5
L	2.00	2.30	2.70
L1	1.17	1.27	1.40
L2			2.20
L3		0.25BSC	
theta	0	-	8°
theta1			5°
theta2			4°
theta3			4°