

AP126P03G

P-Channel Enhancement Mosfet

Features

- -30V, -126A
 $R_{DS(ON)} < 3.9m\ \Omega @ V_{GS} = -10V$ TYP:3.1m Ω
 $R_{DS(ON)} < 6.0m\ \Omega @ V_{GS} = -4.5V$ TYP:4.6m Ω
- Advanced Trench Technology
- High Power and current handing capability
- Lead free product is acquired

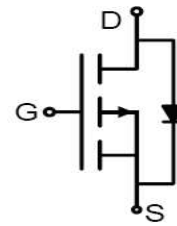

Schematic Diagram

Applications

- Load Switch
- Synchronous Rectification

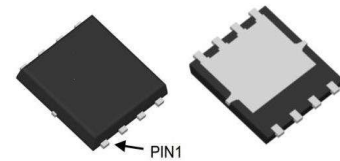

PDFN5X6

Package Marking and Ordering Information

Device Marking	Device	Device Package	Reel Size	Tape width	Quantity (PCS)
126P03G	AP126P03G	PDFN5X6	-	-	5000

ABSOLUTE MAXIMUM RATINGS ($T_a = 25^\circ\text{C}$ unless otherwise noted)

Parameter	Symbol	Value	Unit
Drain-Source Voltage	V_{DS}	-30	V
Gate-Source Voltage	V_{GS}	± 20	V
Continuous Drain Current ($T_c = 25^\circ\text{C}$)	I_D	-126	A
Continuous Drain Current ($T_c = 100^\circ\text{C}$)	I_D	-89	A
Pulsed Drain Current ⁽¹⁾	I_{DM}	-504	A
Single Pulsed Avalanche Energy ⁽²⁾	E_{AS}	576	mJ
Drain Power Dissipation	P_D	107	W
Thermal Resistance from Junction to Case ⁽²⁾	$R_{\theta JC}$	1.4	$^\circ\text{C}/\text{W}$
Thermal Resistance from Junction to Ambient	$R_{\theta JA}$	45	$^\circ\text{C}/\text{W}$
Junction Temperature	T_J	175	$^\circ\text{C}$
Storage Temperature	T_{STG}	-55~ +175	$^\circ\text{C}$

MOSFET ELECTRICAL CHARACTERISTICS($T_a=25^\circ\text{C}$ unless otherwise noted)

Parameter	Symbol	Test Condition	Min	Type	Max	Unit
Static Characteristics						
Drain-source breakdown voltage	$V_{(BR)DSS}$	$V_{GS} = 0V, I_D = -250\mu A$	-30	-	-	V
Zero gate voltage drain current	I_{DSS}	$V_{DS} = -30V, V_{GS} = 0V$	-	-	-1	μA
Gate-body leakage current	I_{GSS}	$V_{GS} = \pm 20V, V_{DS} = 0V$	-	-	± 100	nA
Gate threshold voltage	$V_{GS(th)}$	$V_{DS} = V_{GS}, I_D = -250\mu A$	-1.0	-1.7	-2.5	V
Forward Transconductance	G_{FS}	$V_{DS} = -5V, I_D = -20A$		60		S
Drain-source on-resistance ⁽³⁾	$R_{DS(on)}$	$V_{GS} = -10V, I_D = -20A$	-	3.1	3.9	m Ω
		$V_{GS} = -4.5V, I_D = -20A$		4.6	6.0	m Ω
Dynamic characteristics						
Input Capacitance	C_{iss}	$V_{DS} = -15V, V_{GS} = 0V, f = 1.0MHz$	-	7000	-	pF
Output Capacitance	C_{oss}		-	820	-	
Reverse Transfer Capacitance	C_{rss}		-	540	-	
Switching characteristics						
Turn-on delay time	$t_{d(on)}$	$V_{DS} = -15V, R_L = 0.75\Omega,$ $R_G = 3\Omega, V_G = -10V$	-	14	-	ns
Turn-on rise time	t_r		-	13	-	
Turn-off delay time	$t_{d(off)}$		-	65	-	
Turn-off fall time	t_f		-	37	-	
Total Gate Charge	Q_g	$V_{DS} = -15V, I_D = -20A,$ $V_{GS} = -10V$	-	130	-	nC
Gate-Source Charge	Q_{gs}		-	12	-	
Gate-Drain Charge	Q_{gd}		-	31	-	
Source-Drain Diode characteristics						
Diode Forward voltage ^(a)	V_{SD}	$T_J = 25^\circ\text{C}, V_{GS} = 0V, I_S = -20A$	-	-	-1.2	V
Diode Forward current	I_S	$T_C = 25^\circ\text{C}$	-	-	-126	A
Body Diode Reverse Recovery Time	t_{rr}	$T_J = 25^\circ\text{C}, I_F = -20A, di/dt = 100A/\mu s$		30		ns
Body Diode Reverse Recovery Charge	Q_{rr}	$T_J = 25^\circ\text{C}, I_F = -20A, di/dt = 100A/\mu s$		40		nc

Notes:

- a) Repetitive Rating: Pulse Width Limited by Maximum Junction Temperature
b) EAS condition: $T_J = 25^\circ\text{C}, V_{DD} = -15V, V_G = -10V, R_G = 25\Omega, L = 0.5mH$
c) Pulse Test: Pulse Width $\leq 300\mu s$, Duty Cycle $\leq 0.5\%$

Typical Electrical And Thermal Characteristics (Curves)

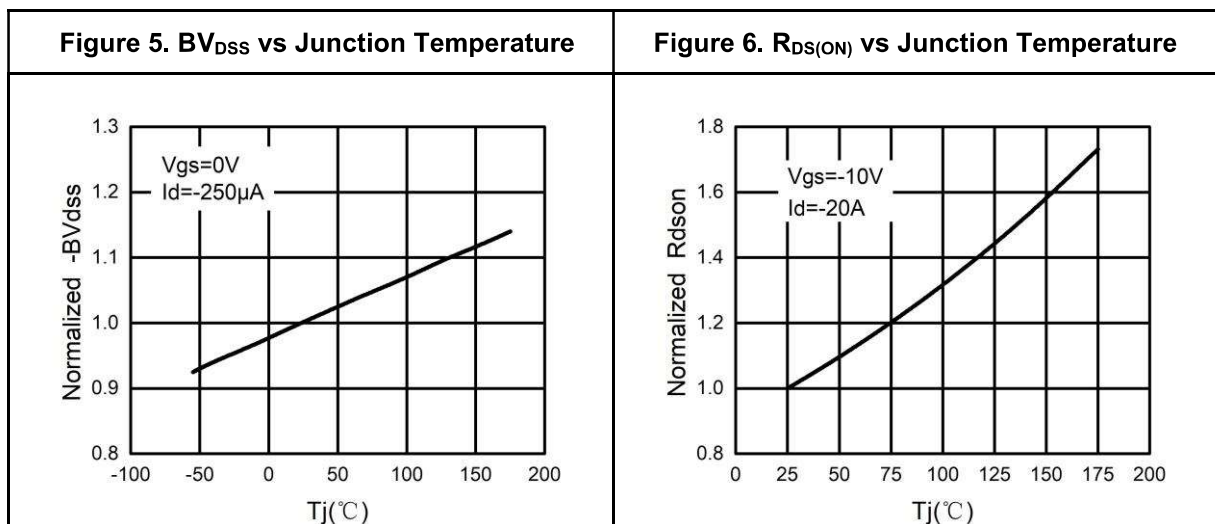
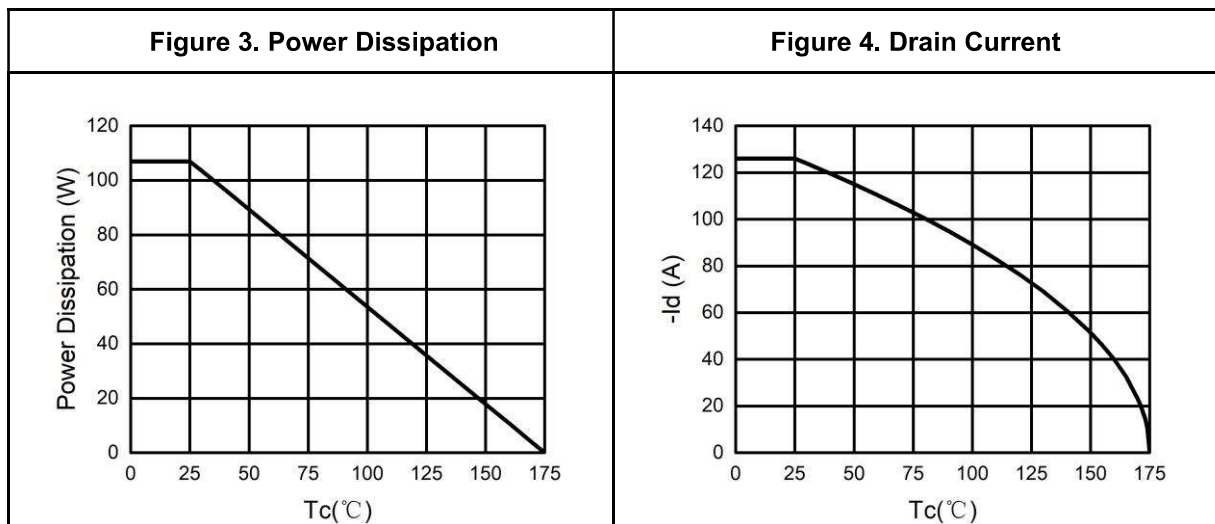
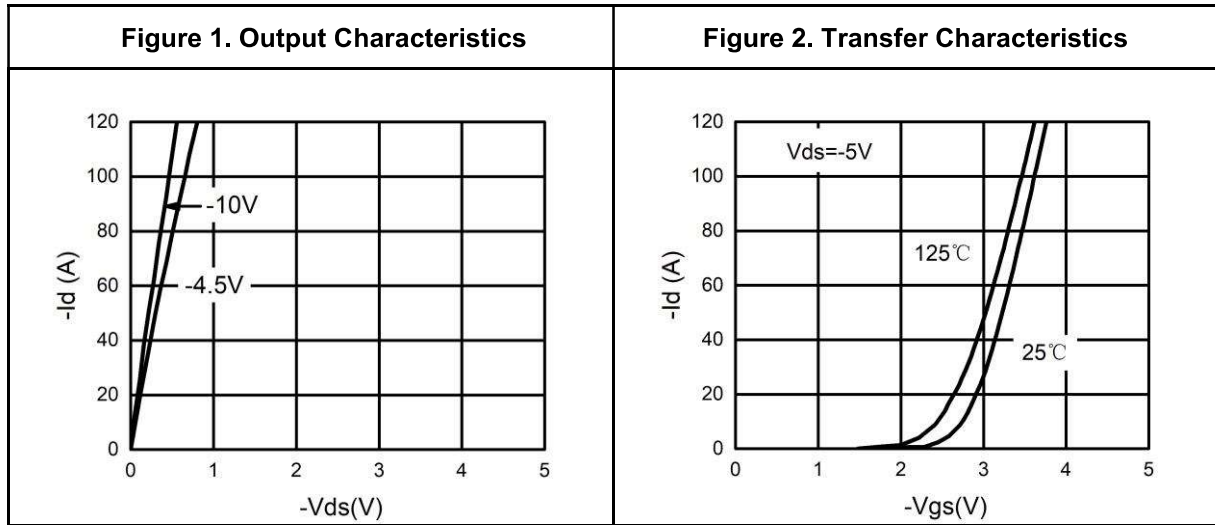

Typical Electrical And Thermal Characteristics (Curves)

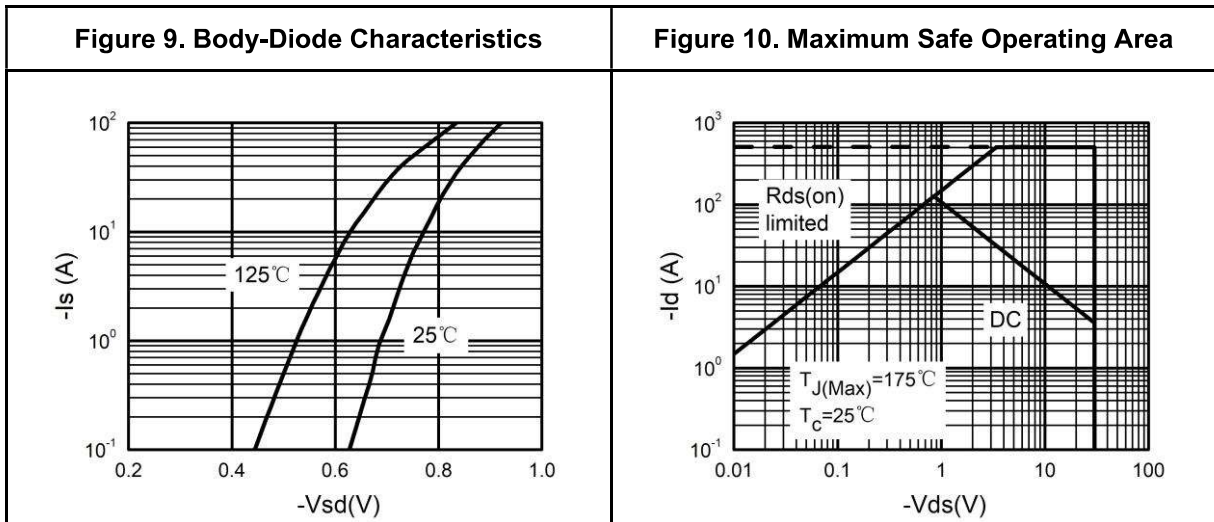
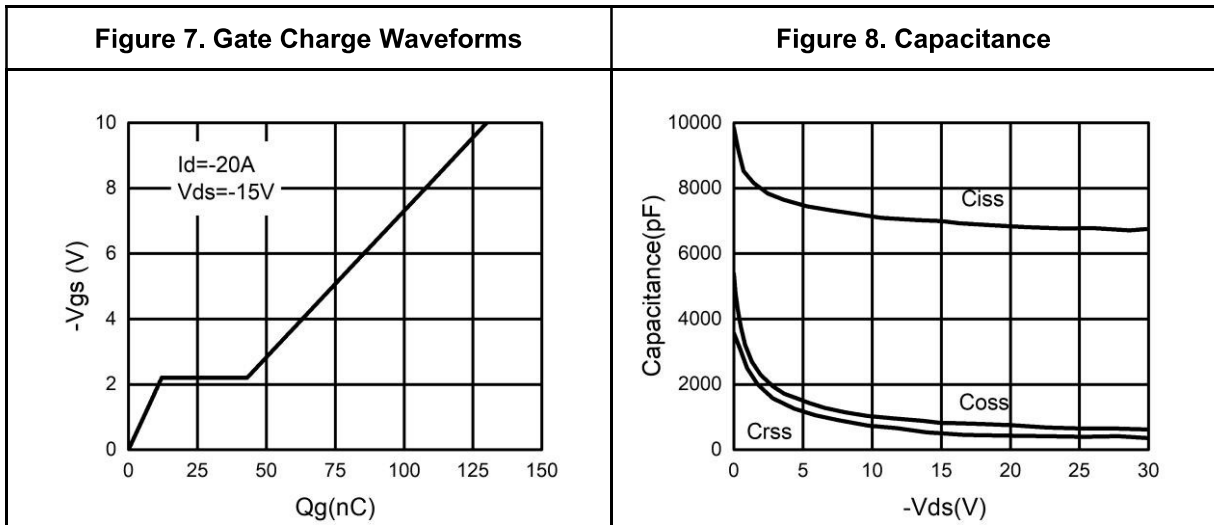

Test Circuit

1) E_{AS} Test Circuits

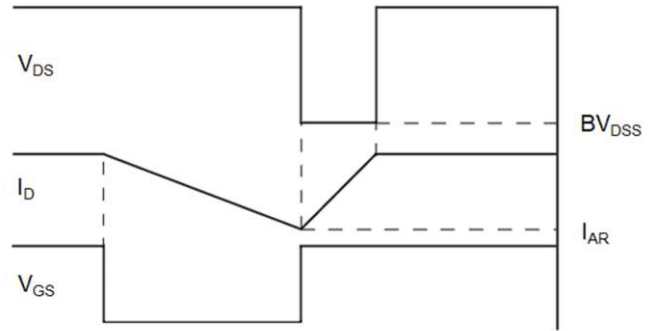
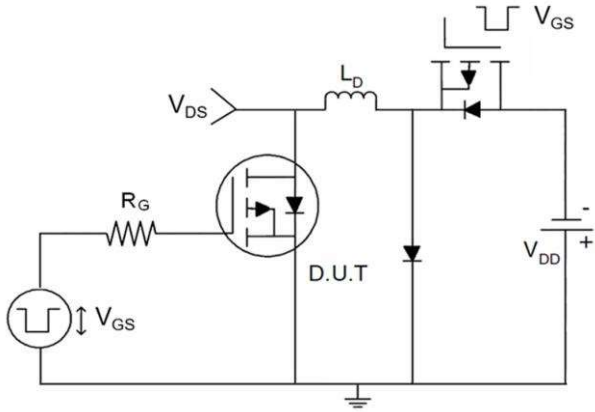

2) Gate Charge Test Circuit

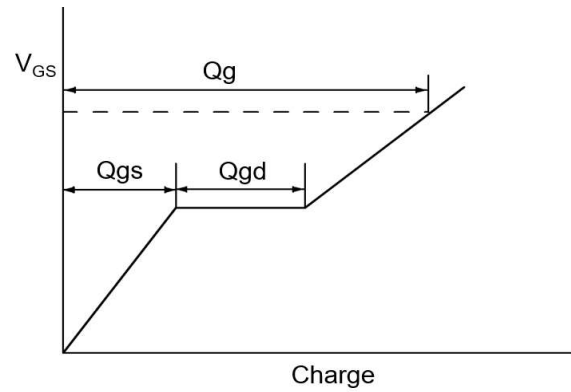
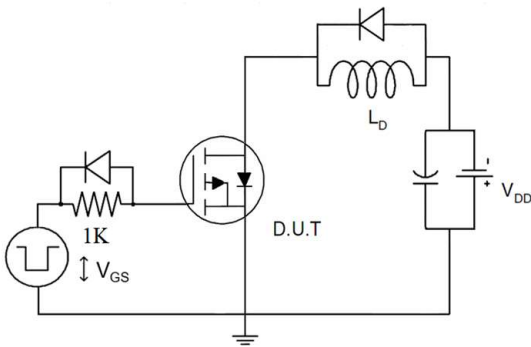

3) Switch Time Test Circuit

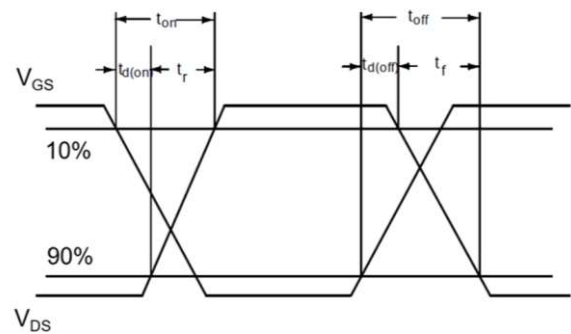
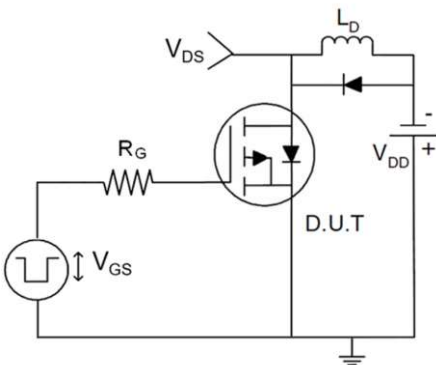

AP126P03G
P-Channel Enhancement Mosfet

PDFN5X6 Package Information

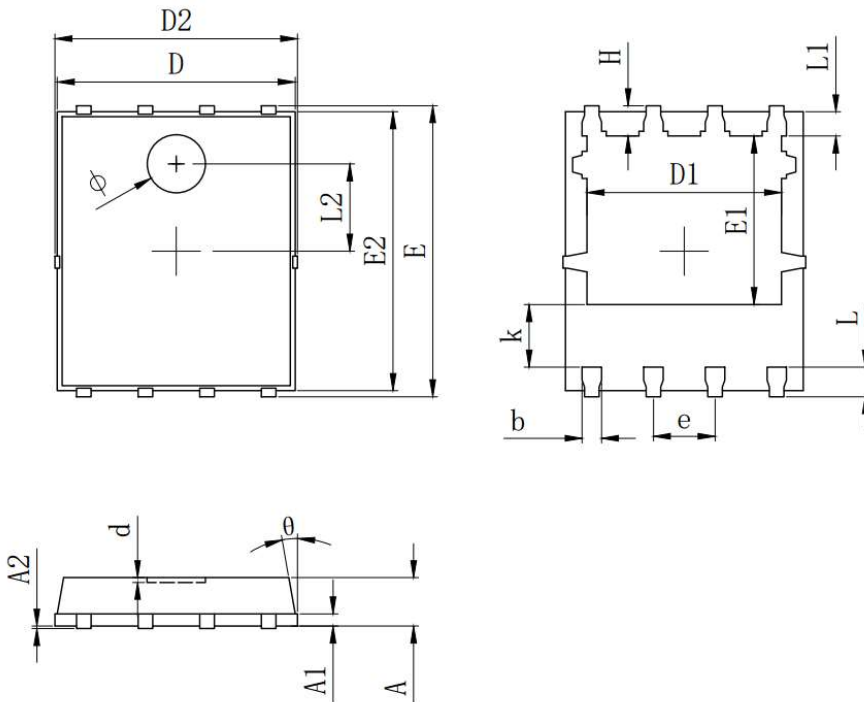

SYMBOL	MILLIMETER		
	MIN	Typ.	MAX
A	0.900	1.000	1.100
A1	0.254 REF.		
A2	0 [~] 0.05		
D	4.824	4.900	4.976
D1	3.910	4.010	4.110
D2	4.924	5.000	5.076
E	5.924	6.000	6.076
E1	3.375	3.475	3.575
E2	5.674	5.750	5.826
b	0.350	0.400	0.450
e	1.270 TYP.		
L	0.534	0.610	0.686
L1	0.424	0.500	0.576
L2	1.800 REF.		
k	1.190	1.290	1.390
H	0.549	0.625	0.701
θ	8°	10°	12°
ϕ	1.100	1.200	1.300
d			0.100

Revision History

Revision	Release	Remark
V1.0	2023/03/21	Initial Release

Disclaimer

The information given in this document describes the independent performance of the product, but similar performance is not guaranteed under other working conditions, and cannot be guaranteed when installed with other products or equipment. To achieve the required performance of the product in actual scenarios, the customer should conduct a complete application test to assess the functionality of the product.

Allpower assumes no responsibility for equipment failures result from using products at values that exceed the ratings, operating conditions, or other parameters listed in the product specifications.

The product described in this specification is not applicable for aerospace or other applications which requires high reliability. Customers using or selling these products for use in medical, life-saving, or life-sustaining applications do so at their own risk and agree to fully indemnify.

Due to product or technical improvements, the information described or contained herein may be changed without prior notice.