

AP130P03D

P-Channel Enhancement Mosfet

AIPOWER

DATA SHEET

Features

- -30V, -130A
 $R_{DS(ON)} < 3.9m\ \Omega @ V_{GS} = -10V$ TYP:3.1m Ω
 $R_{DS(ON)} < 5.7m\ \Omega @ V_{GS} = -4.5V$ TYP:4.4m Ω
- Advanced Trench Technology
- High Power and current handing capability
- Lead free product is acquired

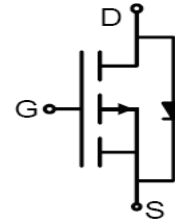

Schematic Diagram

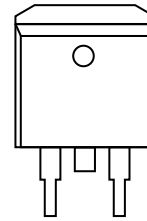

TO-263

Applications

- Load Switch
- Synchronous Rectification

Package Marking and Ordering Information

Device Marking	Device	Device Package	Reel Size	Tape width	Quantity (PCS)
130P03D	AP130P03D	TO-263	-	-	800

ABSOLUTE MAXIMUM RATINGS ($T_a = 25^\circ\text{C}$ unless otherwise noted)

Parameter	Symbol	Value	Unit
Drain-Source Voltage	V_{DS}	-30	V
Gate-Source Voltage	V_{GS}	± 20	V
Continuous Drain Current ($T_C = 25^\circ\text{C}$)	I_D	-130	A
Continuous Drain Current ($T_C = 100^\circ\text{C}$)	I_D	-92	A
Pulsed Drain Current ⁽¹⁾	I_{DM}	-520	A
Single Pulsed Avalanche Energy ⁽²⁾	E_{AS}	576	mJ
Drain Power Dissipation	P_D	115	W
Thermal Resistance from Junction to Case ⁽²⁾	$R_{\theta JC}$	1.3	$^\circ\text{C}/\text{W}$
Thermal Resistance from Junction to Ambient	$R_{\theta JA}$	40	$^\circ\text{C}/\text{W}$
Junction Temperature	T_J	175	$^\circ\text{C}$
Storage Temperature	T_{STG}	-55~ +175	$^\circ\text{C}$

MOSFET ELECTRICAL CHARACTERISTICS($T_a=25^\circ\text{C}$ unless otherwise noted)

Parameter	Symbol	Test Condition	Min	Type	Max	Unit
Static Characteristics						
Drain-source breakdown voltage	$V_{(BR)DSS}$	$V_{GS} = 0V, I_D = -250\mu A$	-30	-	-	V
Zero gate voltage drain current	I_{DSS}	$V_{DS} = -30V, V_{GS} = 0V$	-	-	-1	μA
Gate-body leakage current	I_{GSS}	$V_{GS} = \pm 20V, V_{DS} = 0V$	-	-	± 100	nA
Gate threshold voltage	$V_{GS(th)}$	$V_{DS} = V_{GS}, I_D = -250\mu A$	-1.0	-1.7	-2.5	V
Forward Transconductance	G_{FS}	$V_{DS} = -5V, I_D = -20A$		63		S
Drain-source on-resistance ⁽³⁾	$R_{DS(on)}$	$V_{GS} = -10V, I_D = -20A$	-	3.1	3.9	m Ω
		$V_{GS} = -4.5V, I_D = -20A$		4.4	5.7	m Ω
Dynamic characteristics						
Input Capacitance	C_{iss}	$V_{DS} = -15V, V_{GS} = 0V, f = 1.0MHz$	-	7000	-	pF
Output Capacitance	C_{oss}		-	820	-	
Reverse Transfer Capacitance	C_{rss}		-	540	-	
Switching characteristics						
Turn-on delay time	$t_{d(on)}$	$V_{DS} = -15V, R_L = 0.75\Omega,$ $R_G = 3\Omega, V_G = -10V$	-	14	-	ns
Turn-on rise time	t_r		-	13	-	
Turn-off delay time	$t_{d(off)}$		-	65	-	
Turn-off fall time	t_f		-	37	-	
Total Gate Charge	Q_g	$V_{DS} = -15V, I_D = -20A,$ $V_{GS} = -10V$	-	130	-	nC
Gate-Source Charge	Q_{gs}		-	12	-	
Gate-Drain Charge	Q_{gd}		-	31	-	
Source-Drain Diode characteristics						
Diode Forward voltage ^(a)	V_{SD}	$T_J = 25^\circ\text{C}, V_{GS} = 0V, I_S = -20A$	-	-	-1.2	V
Diode Forward current	I_S	$T_C = 25^\circ\text{C}$	-	-	-130	A
Body Diode Reverse Recovery Time	t_{rr}	$T_J = 25^\circ\text{C}, I_F = -20A, di/dt = 100A/\mu s$		30		ns
Body Diode Reverse Recovery Charge	Q_{rr}	$T_J = 25^\circ\text{C}, I_F = -20A, di/dt = 100A/\mu s$		40		nc

Notes:

- a) Repetitive Rating: Pulse Width Limited by Maximum Junction Temperature
b) EAS condition: $T_J = 25^\circ\text{C}, V_{DD} = -15V, V_G = -10V, R_G = 25\Omega, L = 0.5mH$
c) Pulse Test: Pulse Width $\leq 300\mu s$, Duty Cycle $\leq 0.5\%$

Typical Electrical And Thermal Characteristics (Curves)

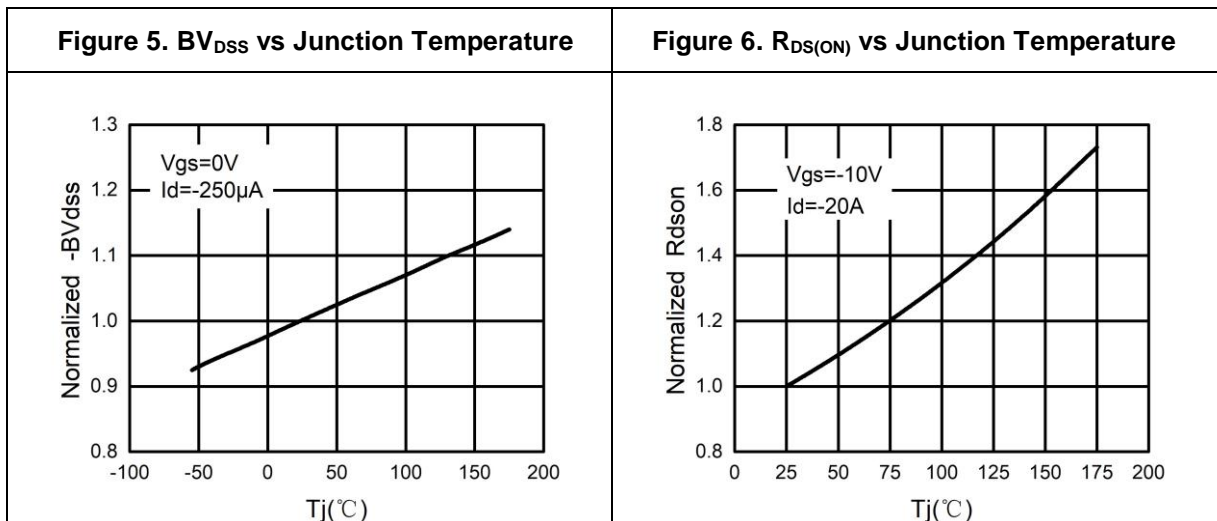
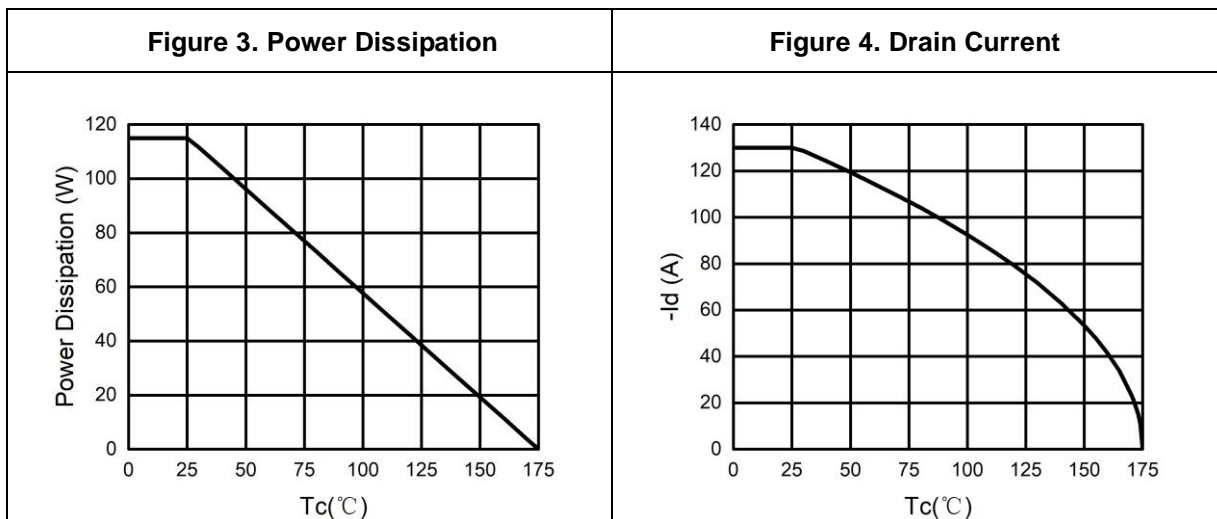
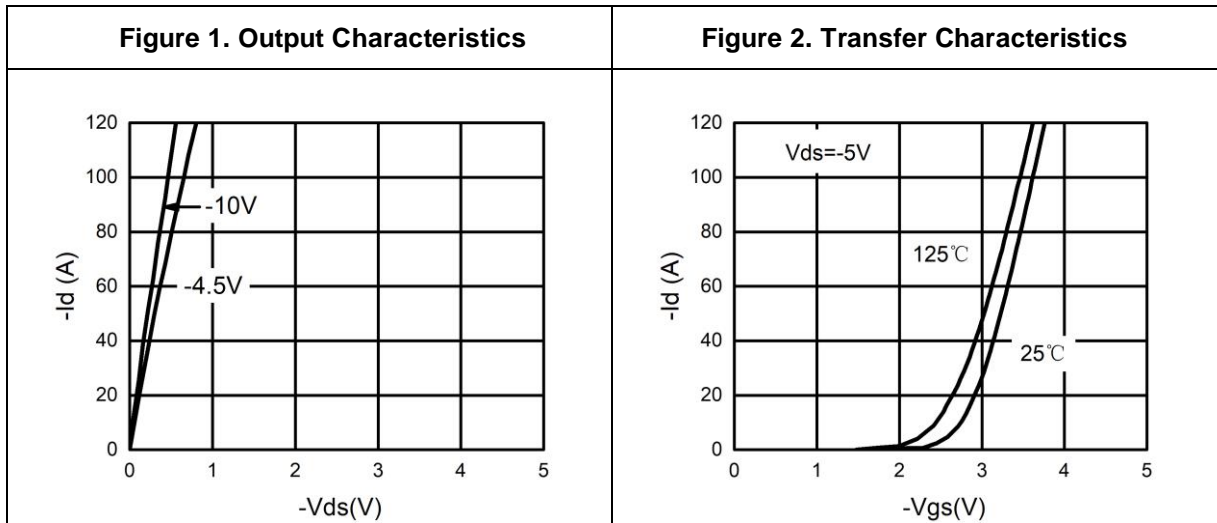

Typical Electrical And Thermal Characteristics (Curves)

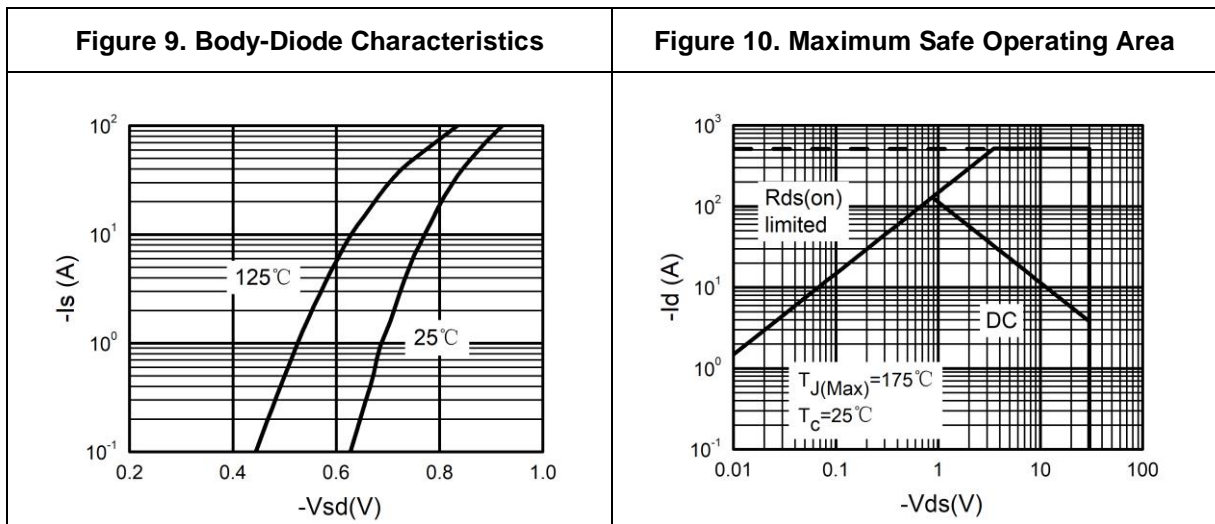
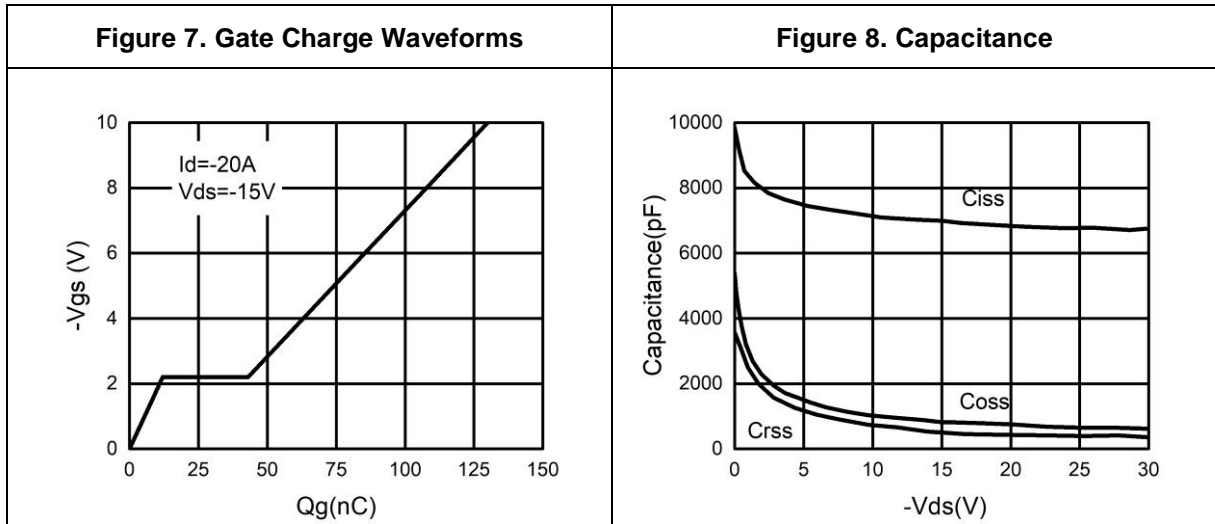

Test Circuit

1) E_{AS} Test Circuits

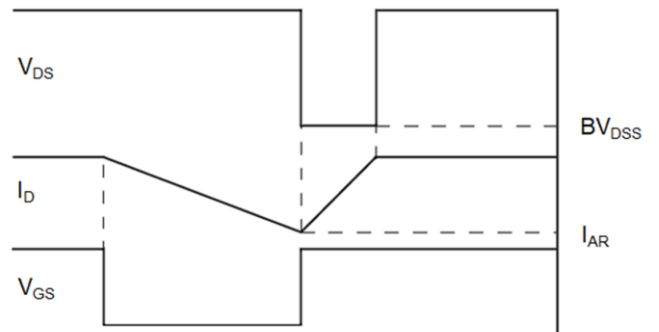
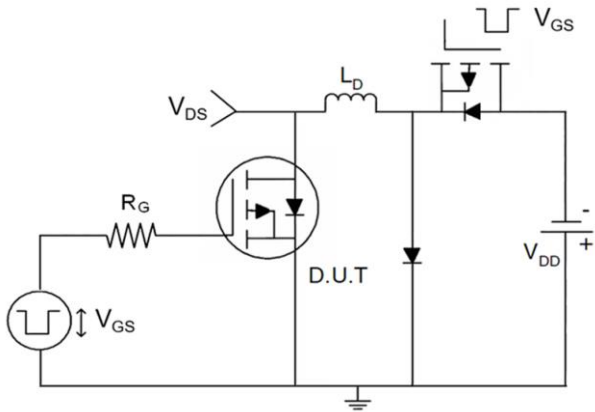

2) Gate Charge Test Circuit

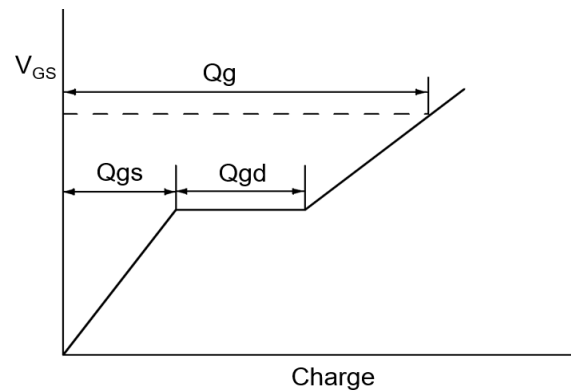
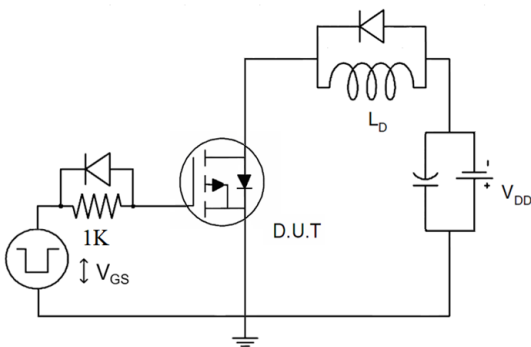

3) Switch Time Test Circuit

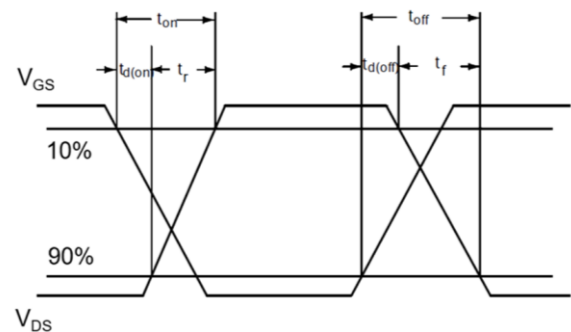
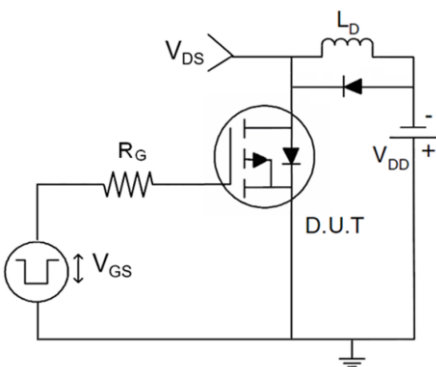

TO-263 Package Information

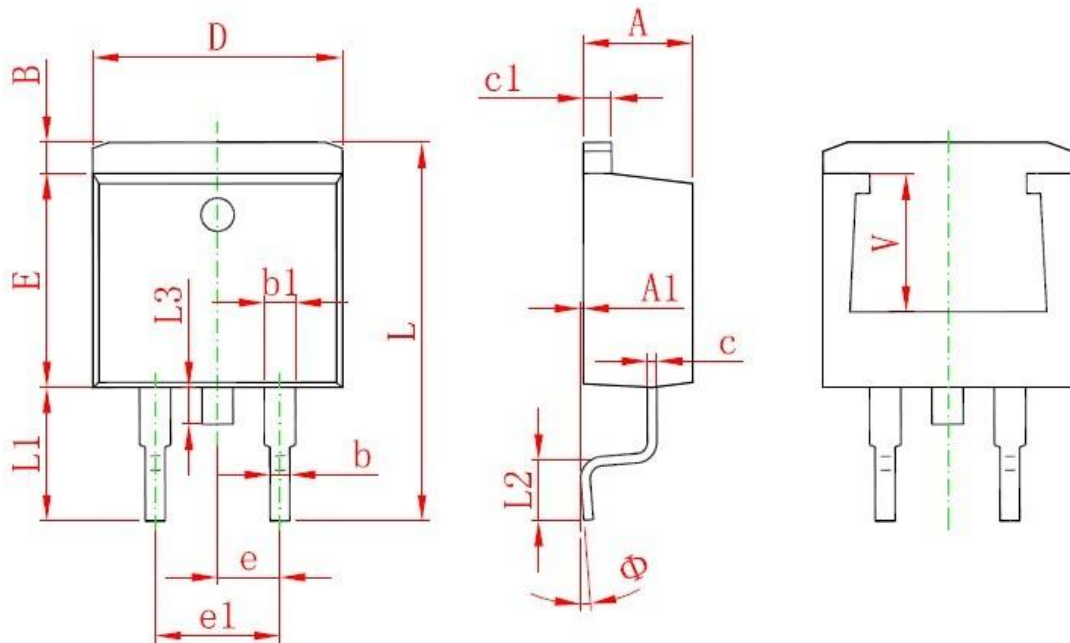

Symbol	Dimensions In Millimeters		Dimensions In Inches	
	Min.	Max.	Min.	Ma
A	4.470	4.670	0.176	0.184
A1	0.000	0.150	0.000	0.006
B	1.120	1.420	0.044	0.056
b	0.710	0.910	0.028	0.036
b1	1.170	1.370	0.046	0.054
c	0.310	0.530	0.012	0.021
c1	1.170	1.370	0.046	0.054
D	10.010	10.310	0.394	0.406
E	8.500	8.900	0.335	0.350
e	2.540 TYP.		0.100TYP.	
e1	4.980	5.180	0.196	0.204
L	14.940	15.500	0.588	0.610
L1	4.950	5.450	0.195	0.215
L2	2.340	2.740	0.092	0.108
L3	1.300	1.700	0.051	0.067
V	5.600 REF.		0.220REF.	
Φ	0°	8°	0°	8°