

Feature

- 40V,200A
 $R_{DS(on)} < 1.1m\Omega @ V_{GS}=10V$ (TYP:0.9m Ω)
 $R_{DS(on)} < 1.5m\Omega @ V_{GS}=4.5V$ (TYP:1.3m Ω)
- Split Gate Trench Technology
- Lead free product is acquired
- Excellent $R_{DS(on)}$ and Low Gate Charge

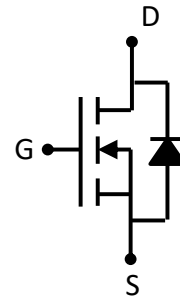

Schematic diagram

Application

- PWM applications
- Load Switch
- Power management

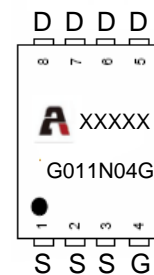

Marking and pin assignment

Package Marking and Ordering Information

Device Marking	Device	Device Package	Reel Size	Tape width	Quantity (PCS)
G011N04G	APG011N04G	PDFN5X6	13 inch	-	5000

ABSOLUTE MAXIMUM RATINGS ($T_a=25^{\circ}C$ unless otherwise noted)

Parameter	Symbol	Value	Unit
Drain-Source Voltage	V_{DS}	40	V
Gate-Source Voltage	V_{GS}	± 20	V
Continuous Drain Current ($T_c = 25^{\circ}C$)	I_D	200	A
Continuous Drain Current ($T_c = 100^{\circ}C$)	I_D	130	A
Pulsed Drain Current ⁽¹⁾	I_{DM}	600	A
Single Pulsed Avalanche Energy ⁽²⁾	E_{AS}	440	mJ
Power Dissipation	P_D	67.5	W
Thermal Resistance from Junction to Case	$R_{\theta JC}$	1.85	$^{\circ}C/W$
Thermal Resistance from Junction to Ambient	$R_{\theta JA}$	50	$^{\circ}C/W$
Junction Temperature	T_J	150	$^{\circ}C$
Storage Temperature	T_{STG}	-55~ +150	$^{\circ}C$

MOSFET ELECTRICAL CHARACTERISTICS($T_a=25^{\circ}\text{C}$ unless otherwise noted)

Parameter	Symbol	Test Condition	Min	Type	Max	Unit
Static Characteristics						
Drain-source breakdown voltage	$V_{(BR)DSS}$	$V_{GS} = 0V, I_D = 250\mu A$	40	-	-	V
Zero gate voltage drain current	I_{DSS}	$V_{DS} = 40V, V_{GS} = 0V$	-	-	1	μA
Gate-body leakage current	I_{GSS}	$V_{GS} = \pm 20V, V_{DS} = 0V$	-	-	± 100	nA
Gate threshold voltage ⁽³⁾	$V_{GS(th)}$	$V_{DS} = V_{GS}, I_D = 250\mu A$	1.2	1.7	2.2	V
Drain-source on-resistance ⁽³⁾	$R_{DS(on)}$	$V_{GS} = 10V, I_D = 30A$	-	0.9	1.1	m Ω
		$V_{GS} = 4.5V, I_D = 30A$	-	1.3	1.5	
Forward Threshold Voltage	g_{fs}	$V_{DS} = 5V, I_D = 20A$	90	-	-	S
Gate Resistance	R_g	$V_{DS} = V_{GS} = 0V, f = 1MHz$	-	5.7	-	Ω
Dynamic characteristics						
Input Capacitance	C_{iss}	$V_{DS} = 20V, V_{GS} = 0V, f = 1MHz$	-	5480	-	pF
Output Capacitance	C_{oss}		-	1770	-	
Reverse Transfer Capacitance	C_{rss}		-	22	-	
Switching characteristics						
Turn-on delay time	$t_{d(on)}$	$V_{DD} = 20V, I_D = 20A,$ $V_{GS} = 10V, R_G = 10\Omega$	-	15	-	ns
Turn-on rise time	t_r		-	38	-	
Turn-off delay time	$t_{d(off)}$		-	183	-	
Turn-off fall time	t_f		-	123	-	
Total Gate Charge	Q_g	$V_{DS} = 32V, I_D = 20A,$ $V_{GS} = 10V$	-	81.4	-	nC
Gate-Source Charge	Q_{gs}		-	20.6	-	
Gate-Drain Charge	Q_{gd}		-	6.2	-	
Reverse Recovery Charge	Q_{rr}	$I_F = 20A, di/dt = 100A/\mu s$		4		nC
Reverse Recovery Time	T_{rr}	$I_F = 20A, di/dt = 100A/\mu s$		17		ns
Source-Drain Diode characteristics						
Diode Forward voltage ⁽³⁾	V_{DS}	$V_{GS} = 0V, I_S = 50A$	-	-	1.2	V
Diode Forward current ⁽⁴⁾	I_S		-	-	200	A

Notes:

1. Repetitive Rating: pulse width limited by maximum junction temperature
2. EAS Condition: $T_J = 25^{\circ}\text{C}, V_{DD} = 20V, R_G = 25\Omega, L = 0.5mH$
3. Pulse Test: pulse width $\leq 300\mu s$, duty cycle $\leq 2\%$
4. Surface Mounted on FR4 Board, $t \leq 10\text{ sec}$

Test Circuit & Waveform

Gate Charge Test Circuit & Waveform

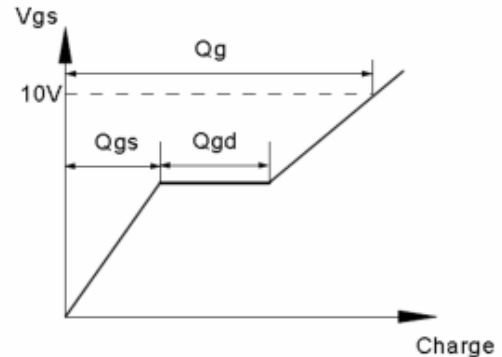
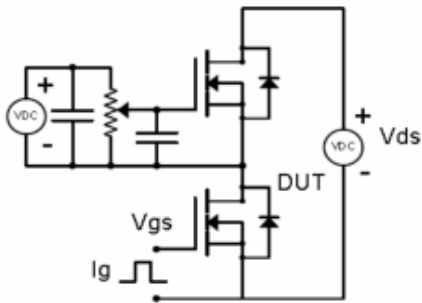

Resistive Switching Test Circuit & Waveforms

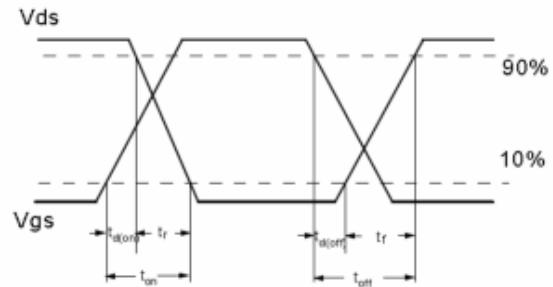
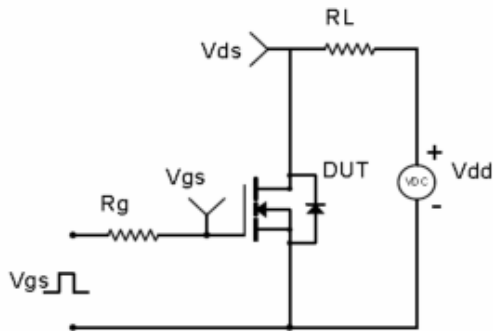

Unclamped Inductive Switching (UIS) Test Circuit & Waveforms

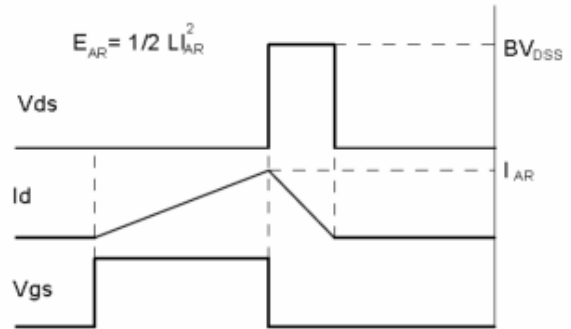
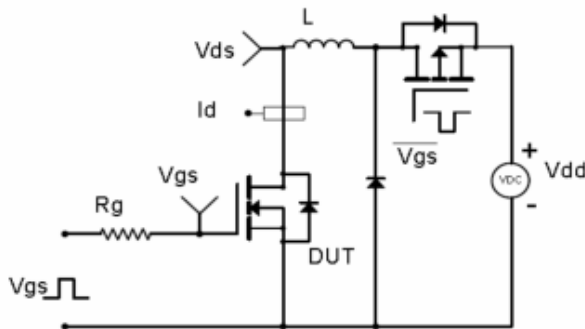

Diode Recovery Test Circuit & Waveforms

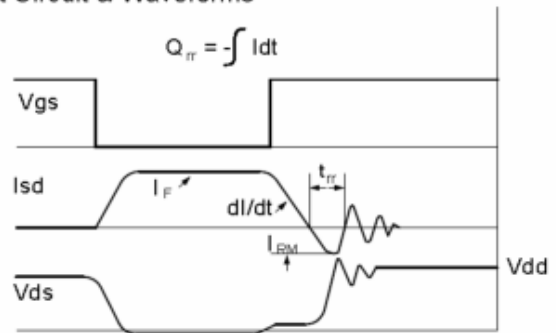
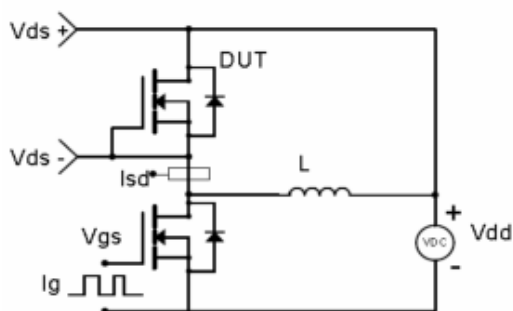

Electrical Characteristics Diagrams

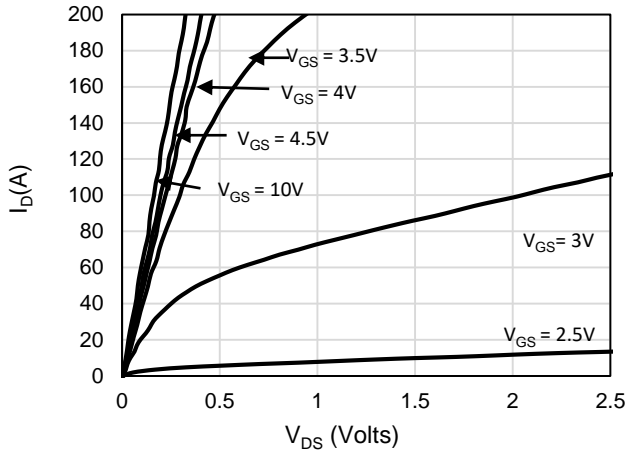

Figure 1: On-Region Characteristics

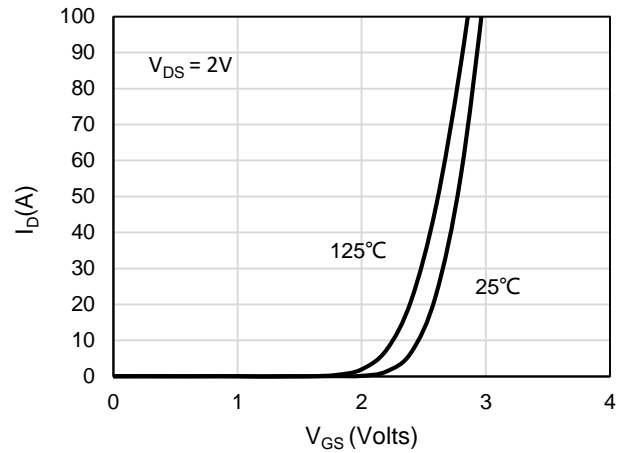

Figure 2: Transfer Characteristics

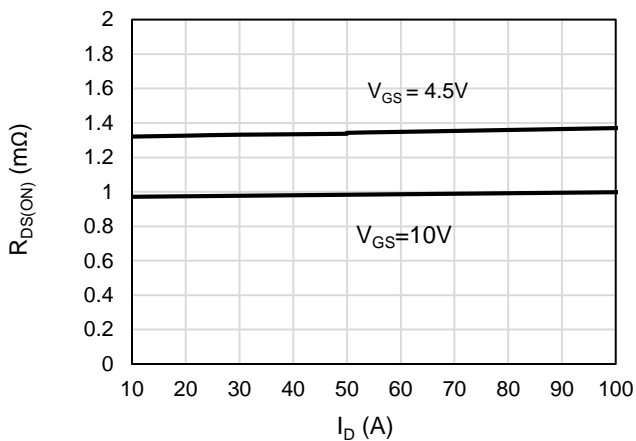

Figure 3: On-Resistance vs. Drain Current and Gate Voltage

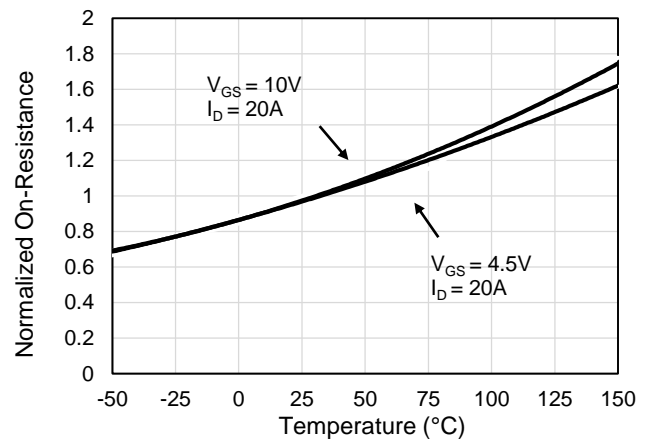

Figure 4: On-Resistance vs. Junction Temperature

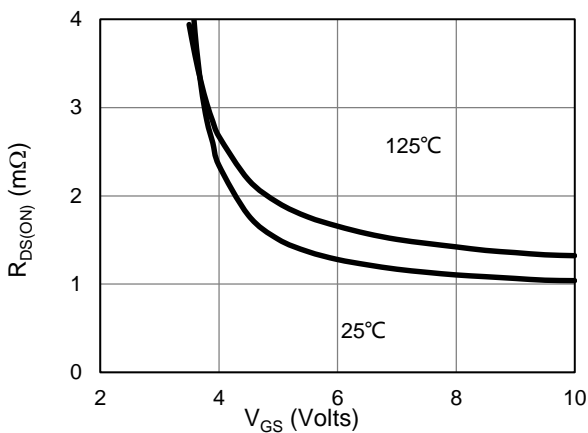

Figure 5: On-Resistance vs. Gate-Source Voltage

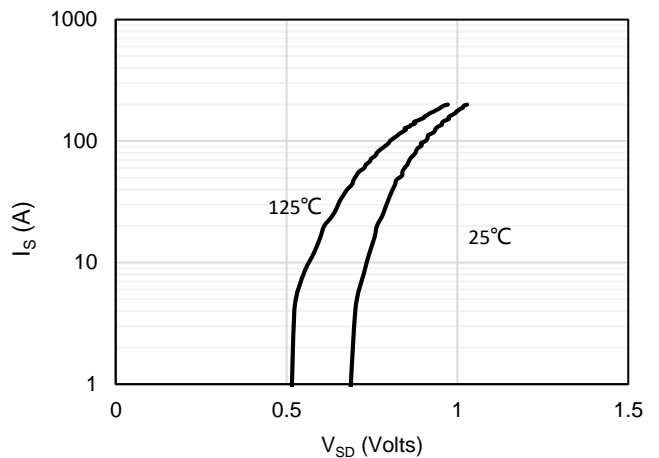

Figure 6: Body-Diode Characteristics

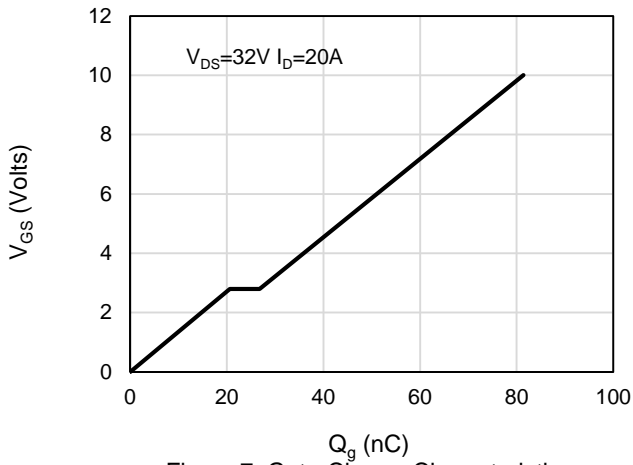

Figure 7: Gate-Charge Characteristics

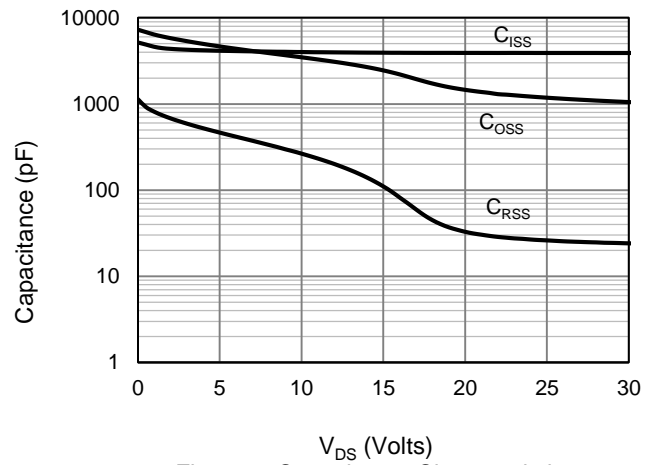

Figure 8: Capacitance Characteristics

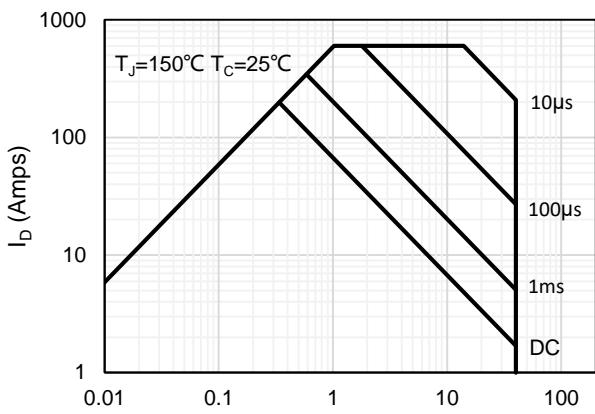

Figure 9: Maximum Forward Biased Safe Operating Area

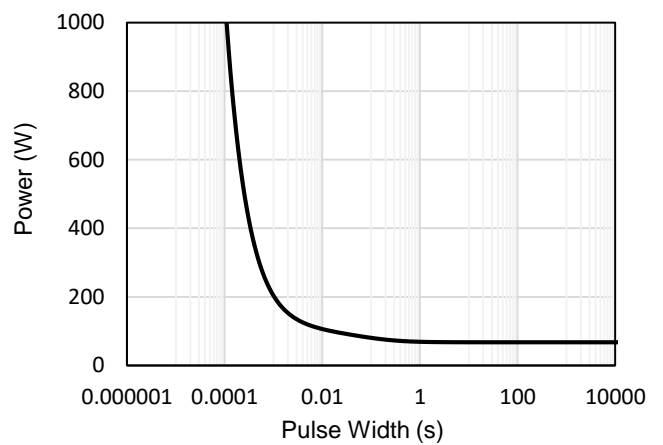

Figure 10: Single Pulse Power Rating Junction-to-Case

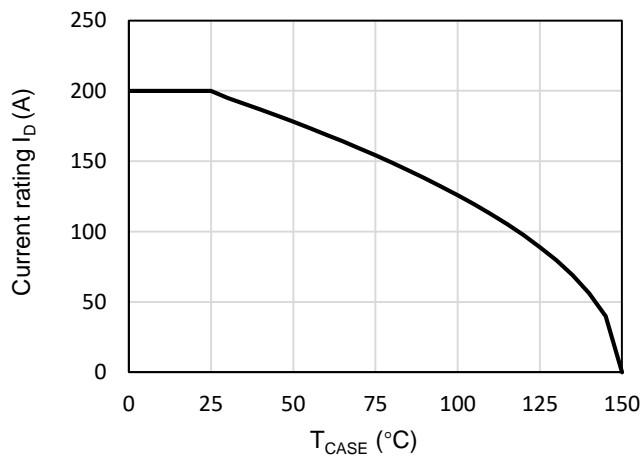

Figure 11: Current De-rating

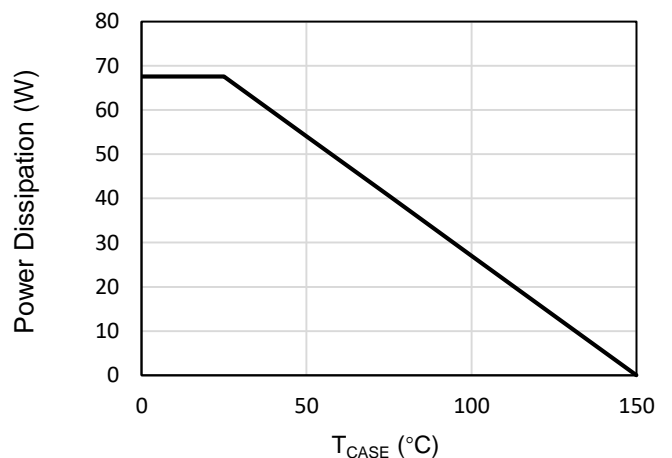

Figure 12: Power De-rating

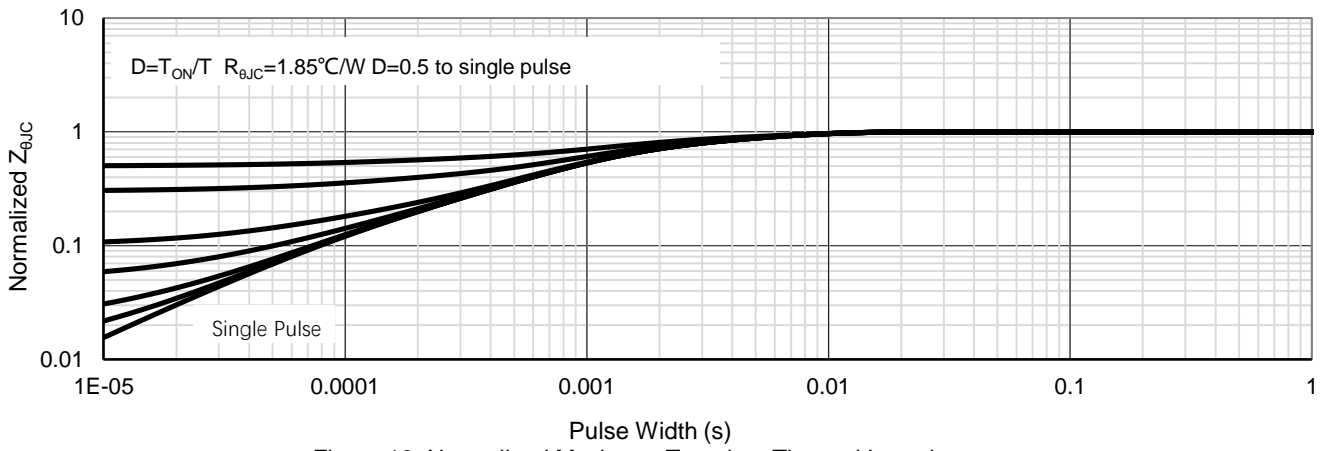
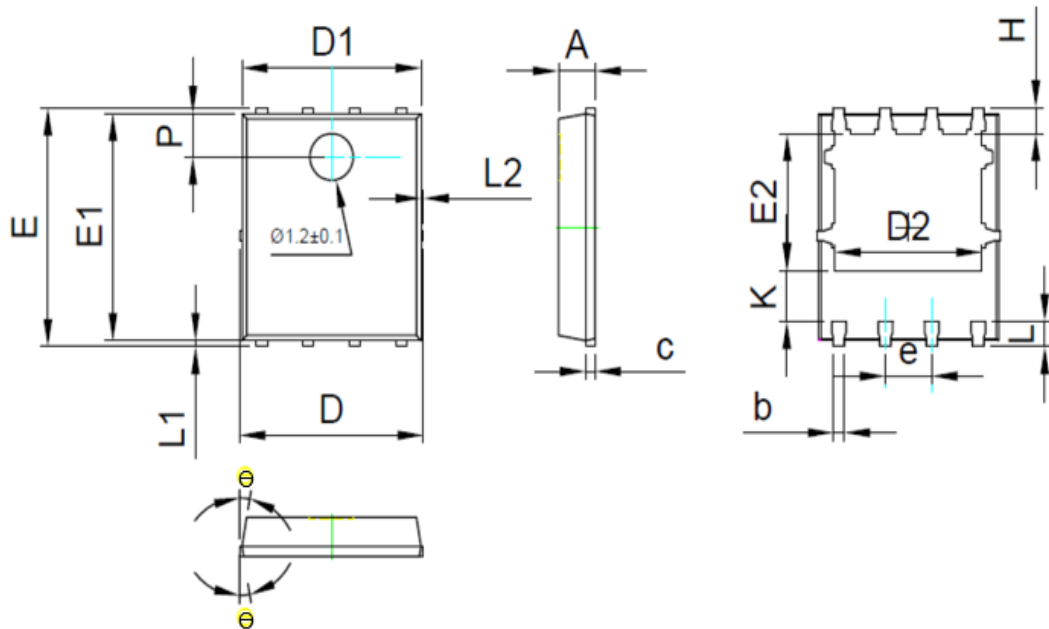

Figure 13: Normalized Maximum Transient Thermal Impedance

PDFN5X6 Package Information



COMMON DIMENSIONS
(UNITS OF MEASURE = MILLIMETER)

SYMBOL	MIN	NOM	MAX
A	0.90	1.00	1.10
b	0.35	0.40	0.45
c	0.21	0.25	0.34
D	-	-	5.1
D1	4.85	4.90	4.95
D2	3.96	4.01	4.06
e	1.27 BSC		
E	5.95	6.00	6.05
E1	5.70	5.75	5.80
E2	3.425	3.475	3.525
H	0.60	0.65	0.70
K	1.29	-	-
L	0.60	0.65	0.70
L1	0.05	0.15	0.25
L2	-	-	0.12
θ	8°	10°	12°
P	1.05	1.10	1.15

Revision History

Revision	Release	Remark
V1.1	2022/12/23	Initial Release

Disclaimer

The information given in this document describes the independent performance of the product, but similar performance is not guaranteed under other working conditions, and cannot be guaranteed when installed with other products or equipment. To achieve the required performance of the product in actual scenarios, the customer should conduct a complete application test to assess the functionality of the product.

Allpower assumes no responsibility for equipment failures result from using products at values that exceed the ratings, operating conditions, or other parameters listed in the product specifications.

The product described in this specification is not applicable for aerospace or other applications which requires high reliability. Customers using or selling these products for use in medical, life-saving, or life-sustaining applications do so at their own risk and agree to fully indemnify.

Due to product or technical improvements, the information described or contained herein may be changed without prior notice.