

APG054N10D

N-Channel Shielding-Gate Mosfet

AIPOWER

DATA SHEET

Feature

- 100V,120A
 $R_{DS(ON)} < 5.4m\Omega @ V_{GS}=10V$ TYP:4.5m Ω
- Split Gate Trench Technology
- Provide Excellent $R_{DS(ON)}$ And Low Gate Charge

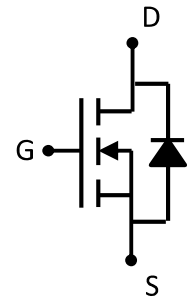

Schematic diagram

Application

- DC/DC Converter
- Load Switch for Portable Devices
- Battery Switch
- Rectifier

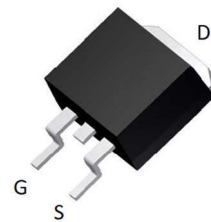

TO-263 top view

Package Marking and Ordering Information

Device Marking	Device	Device Package	Reel Size	Tape width	Quantity (PCS)
G054N10D	APG054N10D	TO-263		-	800

ABSOLUTE MAXIMUM RATINGS ($T_J=25^{\circ}C$ unless otherwise noted)

Parameter	Symbol	Value	Unit
Drain-Source Voltage	V_{DS}	100	V
Gate-Source Voltage	V_{GS}	± 20	V
Continuous Drain Current ($T_C=25^{\circ}C$)	I_D	120	A
Continuous Drain Current ($T_C=100^{\circ}C$)	I_D	84	A
Pulsed Drain Current ⁽¹⁾	I_{DM}	440	A
Single Pulsed Avalanche Energy ⁽²⁾	E_{AS}	225	mJ
Power Dissipation	P_D	192	W
Thermal Resistance from Junction to Case	$R_{\theta JC}$	0.65	$^{\circ}C/W$
Junction Temperature	T_J	150	$^{\circ}C$
Storage Temperature	T_{STG}	-55~ +150	$^{\circ}C$

MOSFET ELECTRICAL CHARACTERISTICS(T_J=25°C unless otherwise noted)

Parameter	Symbol	Test Condition	Min	Type	Max	Unit
Static Characteristics						
Drain-source breakdown voltage	V _{(BR)DSS}	V _{GS} = 0V, I _D =250μA	100	-	-	V
Zero gate voltage drain current	I _{DSS}	V _{DS} =100V, V _{GS} = 0V	-	-	1	μA
Gate-body leakage current	I _{GSS}	V _{GS} = ±20V, V _{DS} = 0V	-	-	±100	nA
Gate threshold voltage ⁽³⁾	V _{GS(th)}	V _{DS} =V _{GS} , I _D =250μA	2	3	4	V
Drain-source on-resistance ⁽³⁾	R _{DS(on)}	V _{GS} =10V, I _D =20A	-	4.5	5.4	mΩ
Gate Resistance	R _G	f =1MHz	-	3.5	-	Ω
Dynamic characteristics						
Input Capacitance	C _{iss}	V _{DS} =50V, V _{GS} =0V, f =1MHz	-	3244	-	pF
Output Capacitance	C _{oss}		-	1075	-	
Reverse Transfer Capacitance	C _{rss}		-	52	-	
Switching characteristics						
Turn-on delay time	t _{d(on)}	V _{DD} =50V, R _L =2.5Ω V _{GS} =10V, R _G =6Ω	-	22	-	ns
Turn-on rise time	t _r		-	36	-	
Turn-off delay time	t _{d(off)}		-	49	-	
Turn-off fall time	t _f		-	31	-	
Total Gate Charge	Q _g	V _{DS} =50V, I _D =20A, V _{GS} =10V	-	51	-	nC
Gate-Source Charge	Q _{gs}		-	15	-	
Gate-Drain Charge	Q _{gd}		-	13	-	
Source-Drain Diode characteristics						
Diode Forward voltage ⁽³⁾	V _{DS}	V _{GS} =0V, I _S =20A	-	-	1.2	V
Diode Forward current ⁽⁴⁾	I _S		-	-	120	A
Reverse recovery time	T _{rr}	I _S =15A, V _{GS} =0V, dI _F /dt=100A/us		58		ns
Reverse recovery charge	Q _{rr}	I _S =15A, V _{GS} =0V, dI _F /dt=100A/us		90		nC

Notes:

1. Repetitive Rating: pulse width limited by maximum junction temperature
2. EAS Condition: T_J=25°C, V_{DD}=50V, R_G=25 Ω, L=0.5mH
3. Pulse Test: pulse width≤300μs, duty cycle≤2%
4. Surface Mounted on FR4 Board, t≤10 sec

Test Circuit & Waveform

Gate Charge Test Circuit & Waveform

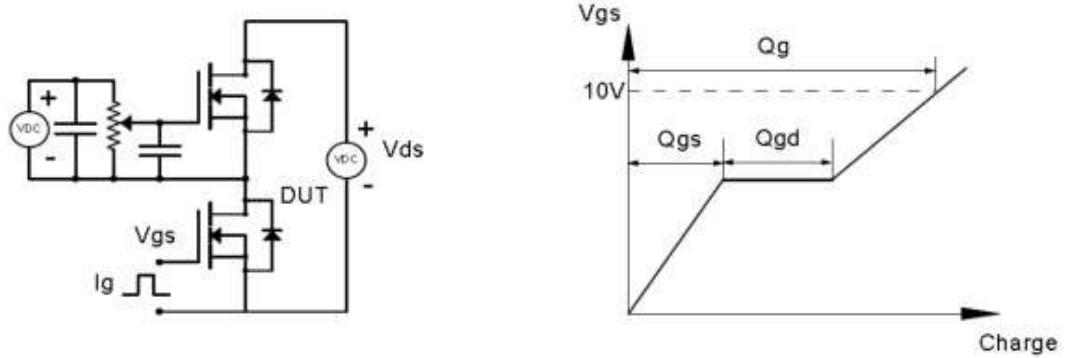

Resistive Switching Test Circuit & Waveforms

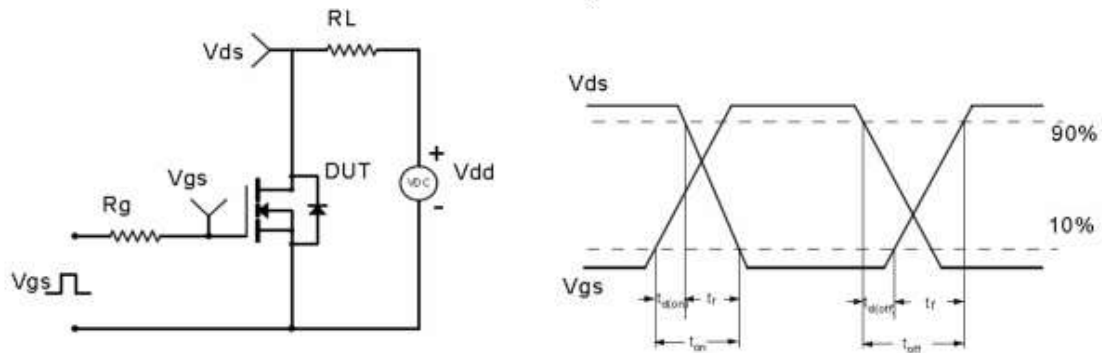

Unclamped Inductive Switching (UIS) Test Circuit & Waveforms

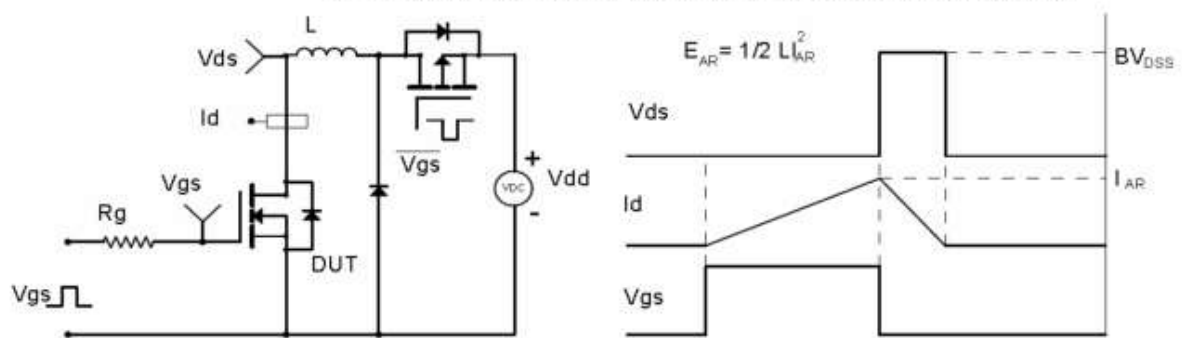

Diode Recovery Test Circuit & Waveforms

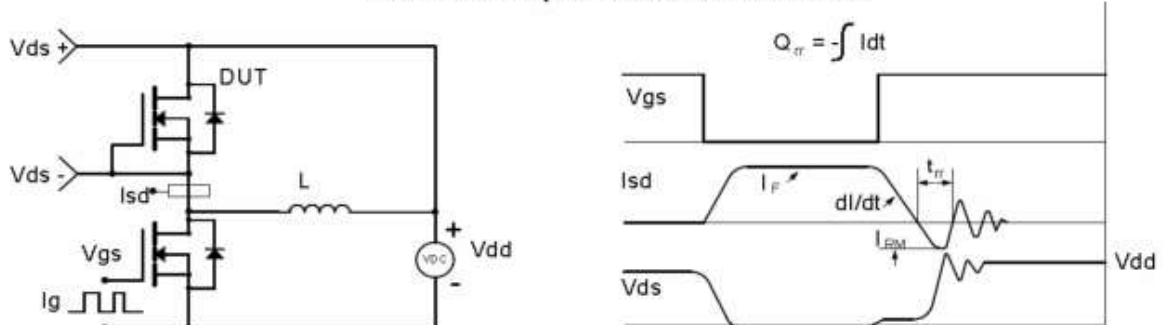

Electrical Characteristics Diagrams

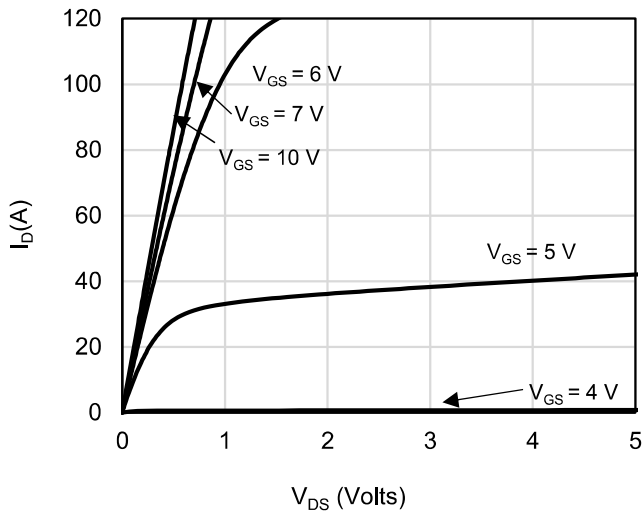

Figure 1: On-Region Characteristics

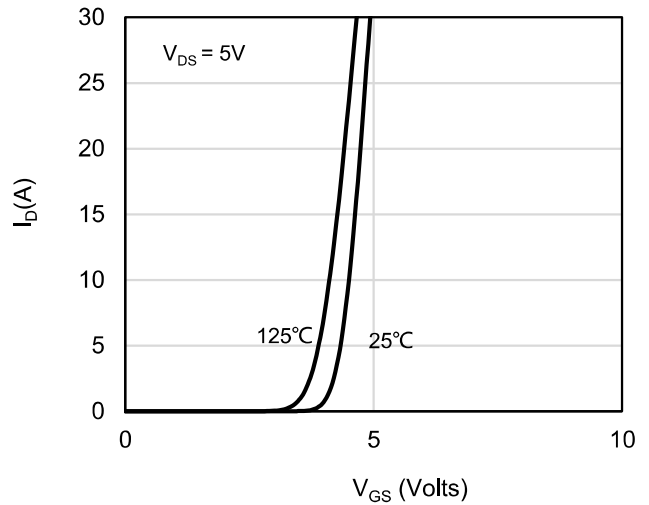

Figure 2: Transfer Characteristics

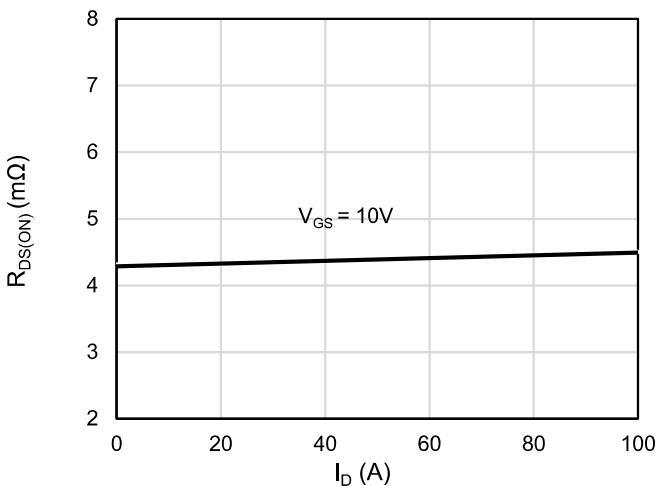

Figure 3: On-Resistance vs. Drain Current and Gate Voltage

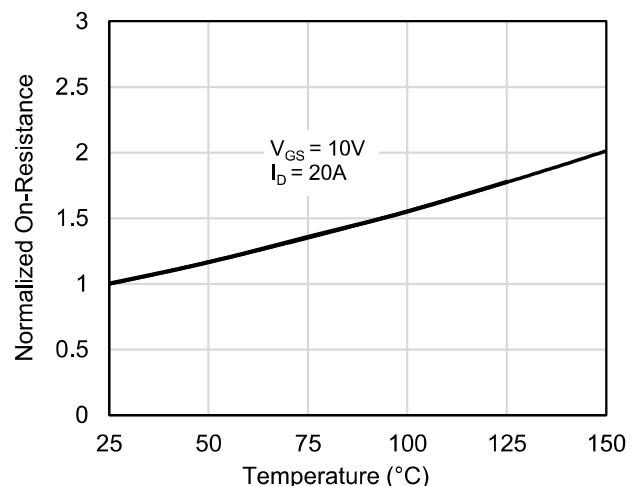

Figure 4: On-Resistance vs. Junction Temperature

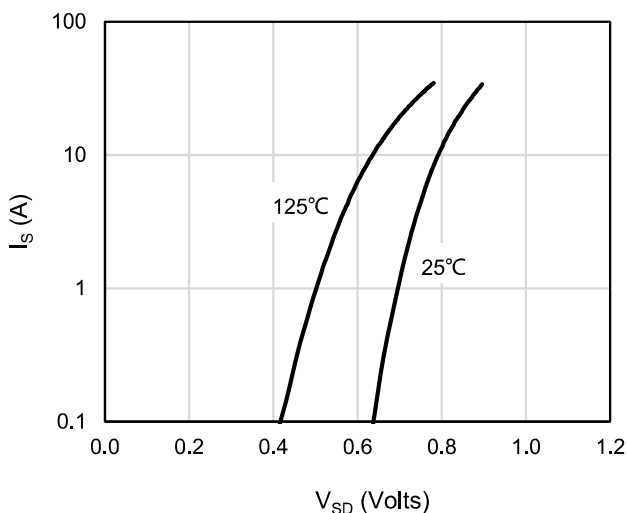

Figure 7: Body-Diode Characteristics

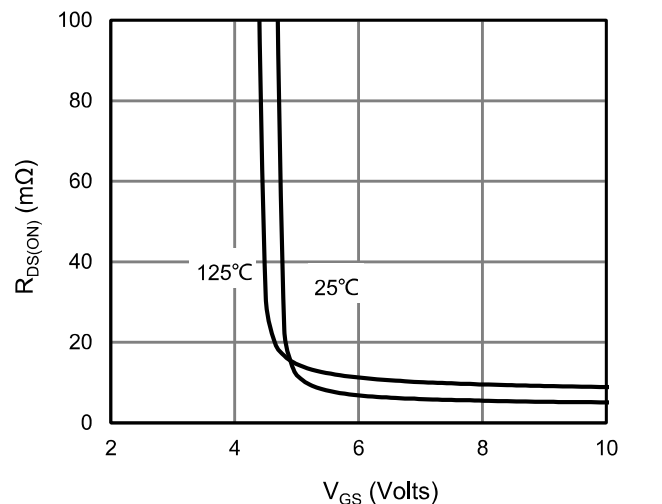

Figure 8: On-Resistance vs. Gate-Source Voltage

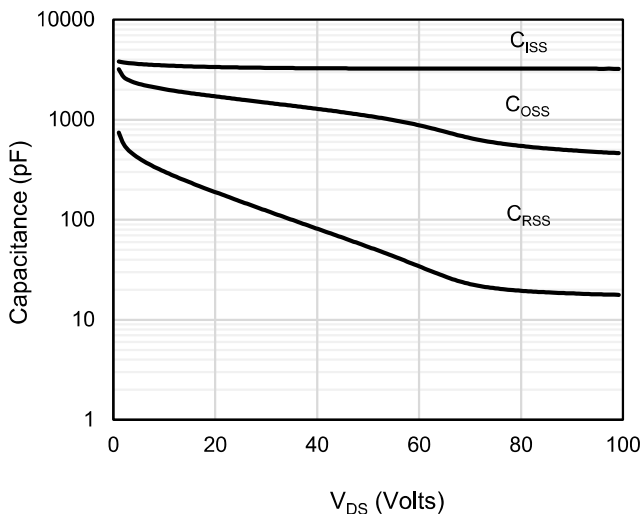

Figure 9: Capacitance Characteristics

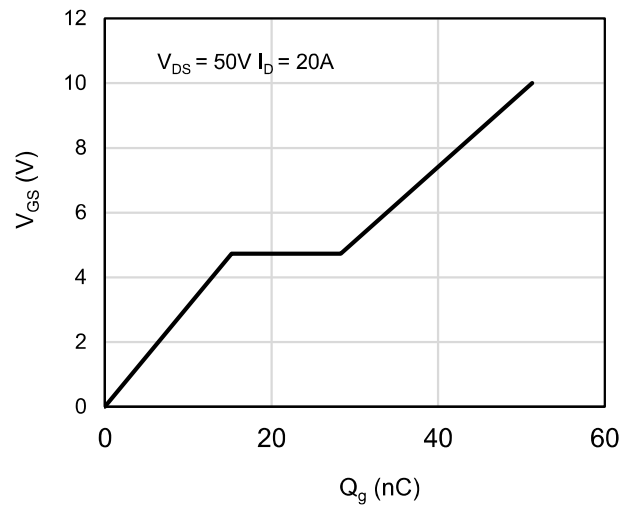

Figure 10: Gate-Charge Characteristics

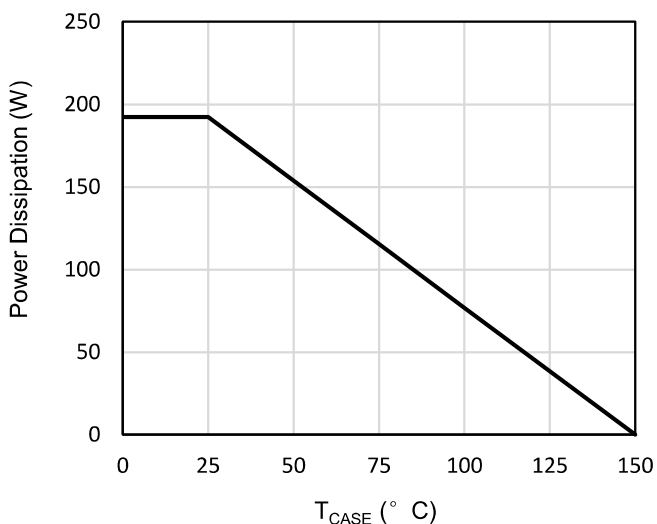

Figure 11: Power De-rating

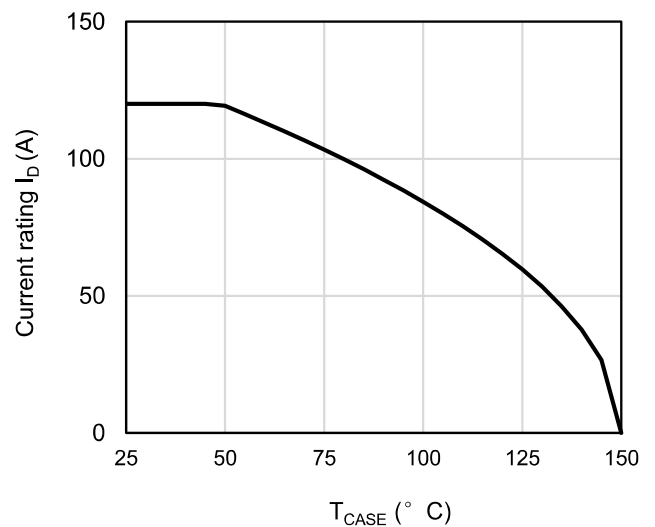

Figure 12: Current De-rating

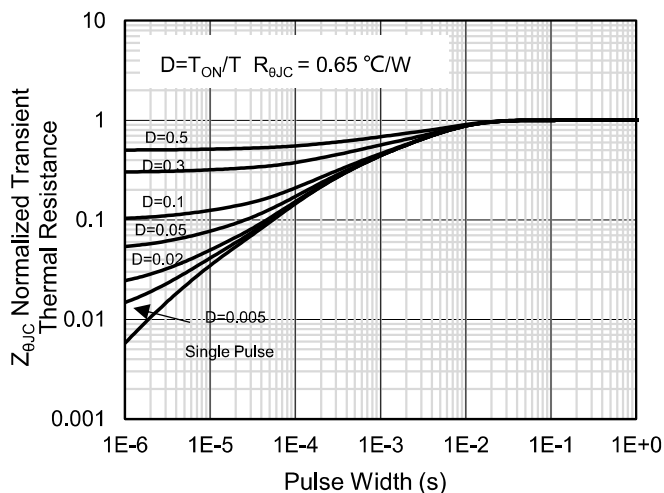

Figure 13: Normalized Maximum Transient Thermal Impedance

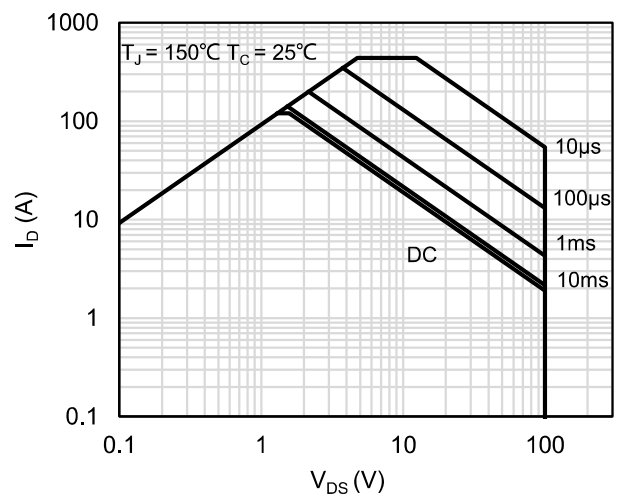
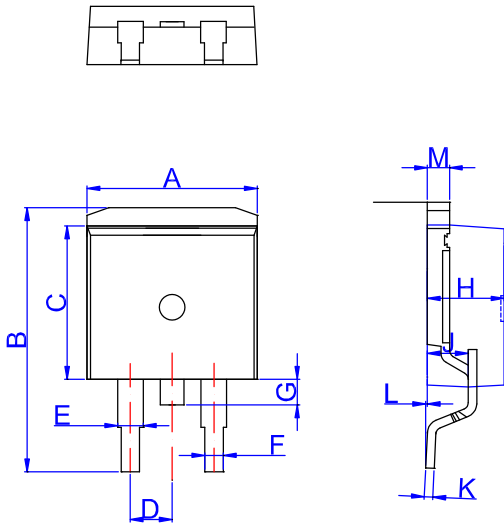

Figure 14: Maximum Forward Biased Safe Operating Area

TO-263 Package Information



TO-263

Ref.	Dimensions					
	Millimeters			Inches		
	Min.	Typ.	Max.	Min.	Typ.	Max.
A	9.90		10.20	0.390		0.402
B	14.70		15.80	0.579		0.622
C	9.4		9.6	0.37		0.378
D		2.54			0.100	
E	1.20		1.40	0.047		0.055
F	0.75		0.85	0.029		0.033
G			1.75			0.069
H	4.40		4.70	0.173		0.185
J	2.30		2.70	0.091		0.106
K	0.38		0.55	0.015		0.022
L	0	0.10	0.25	0	0.004	0.010
M	1.25		1.35	0.049		0.053