

APG082N01

N-Channel Enhancement Mosfet

AIPOWER

DATA SHEET

Feature

- 100V,100A
 $R_{DS(ON)} < 8.2m\Omega @ V_{GS}=10V$ (TYP:6.7m Ω)
- Split Gate Trench Technology
- Lead free product is acquired
- Excellent $R_{DS(ON)}$ and Low Gate Charge

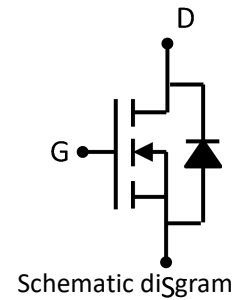

Application

- PWM applications
- Load Switch
- Power management

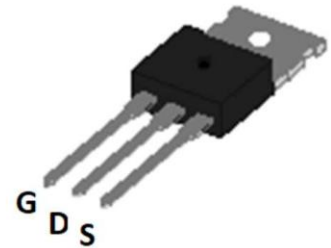

TO-220

Package Marking and Ordering Information

Device Marking	Device	Device Package	Reel Size	Tape width	Quantity (PCS)
G082N01	APG082N01	TO-220		-	1000

ABSOLUTE MAXIMUM RATINGS ($T_J=25^{\circ}C$ unless otherwise noted)

Parameter	Symbol	Value	Unit
Drain-Source Voltage	V_{DS}	100	V
Gate-Source Voltage	V_{GS}	± 25	V
Continuous Drain Current ($T_C = 25^{\circ}C$)	I_D	100	A
Continuous Drain Current ($T_C = 100^{\circ}C$)	I_D	70	A
Pulsed Drain Current ⁽¹⁾	I_{DM}	320	A
Single Pulsed Avalanche Energy ⁽²⁾	E_{AS}	300	mJ
Power Dissipation	P_D	120	W
Thermal Resistance from Junction to Case	$R_{\theta JC}$	1.05	$^{\circ}C/W$
Junction Temperature	T_J	150	$^{\circ}C$
Storage Temperature	T_{STG}	-55~ +150	$^{\circ}C$

MOSFET ELECTRICAL CHARACTERISTICS(T_a=25°C unless otherwise noted)

Parameter	Symbol	Test Condition	Min	Type	Max	Unit
Static Characteristics						
Drain-source breakdown voltage	V _{(BR)DSS}	V _{GS} = 0V, I _D =250μA	100	-	-	V
Zero gate voltage drain current	I _{DSS}	V _{DS} =100V, V _{GS} = 0V	-	-	1	μA
Gate-body leakage current	I _{GSS}	V _{GS} = ±20V, V _{DS} = 0V	-	-	±100	nA
Gate threshold voltage ⁽³⁾	V _{GS(th)}	V _{DS} =V _{GS} , I _D =250μA	2.0	3.0	4.0	V
Drain-source on-resistance ⁽³⁾	R _{DS(on)}	V _{GS} =10V, I _D =40A	-	6.7	8.2	mΩ
Forward Threshold Voltage	g _{fs}	V _{DS} =10V, I _D =40A	-	60	-	S
Gate Resistance	R _g	V _{DS} =V _{GS} =0V, f =1MHz	-	1.3	-	Ω
Dynamic characteristics						
Input Capacitance	C _{iss}	V _{DS} =50V, V _{GS} =0V, f =1MHz	-	2435	-	pF
Output Capacitance	C _{oss}		-	380	-	
Reverse Transfer Capacitance	C _{rss}		-	11	-	
Switching characteristics						
Turn-on delay time	t _{d(on)}	V _{DD} =50V, I _D =40A, V _{GS} =10V, R _G =3Ω	-	13	-	ns
Turn-on rise time	t _r		-	35	-	
Turn-off delay time	t _{d(off)}		-	20	-	
Turn-off fall time	t _f		-	15	-	
Total Gate Charge	Q _g	V _{DS} =50V, I _D =40A, V _{GS} =10V	-	47	-	nC
Gate-Source Charge	Q _{gs}		-	9	-	
Gate-Drain Charge	Q _{gd}		-	24	-	
Reverse Recovery Chrage	Q _{rr}	I _F =40A, di/dt=100A/us		50		nC
Reverse Recovery Time	T _{rr}	I _F =40A, di/dt=100A/us		48		ns
Source-Drain Diode characteristics						
Diode Forward voltage ⁽³⁾	V _{DS}	V _{GS} =0V, I _S =20A	-	-	1.2	V
Diode Forward current ⁽⁴⁾	I _S		-	-	100	A

Notes:

1. Repetitive Rating: pulse width limited by maximum junction temperature
2. EAS Condition: T_J=25°C, V_{DD}=50V, R_G=25 Ω, L=0.5Mh, I_{AS}=35A
3. Pulse Test: pulse width≤300μs, duty cycle≤2%
4. Surface Mounted on FR4 Board, t≤10 sec

Test Circuit & Waveform

Gate Charge Test Circuit & Waveform

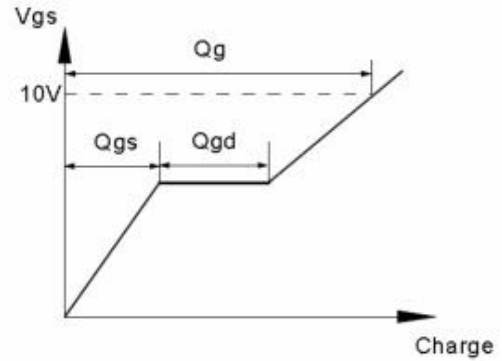
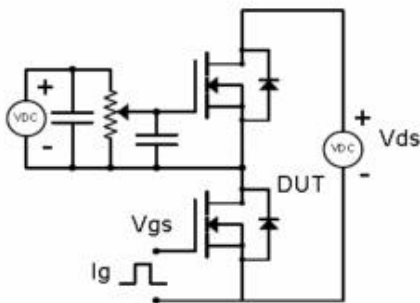

Resistive Switching Test Circuit & Waveforms

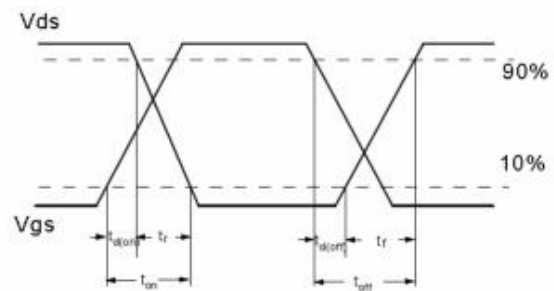
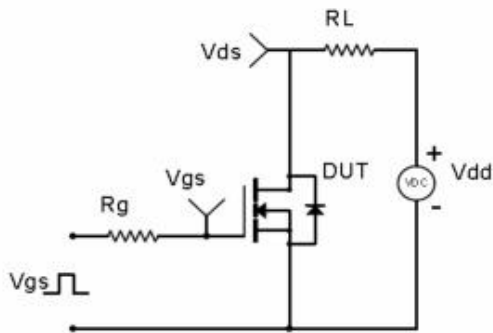

Unclamped Inductive Switching (UIS) Test Circuit & Waveforms

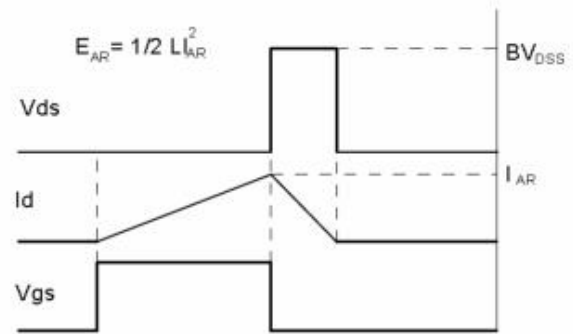
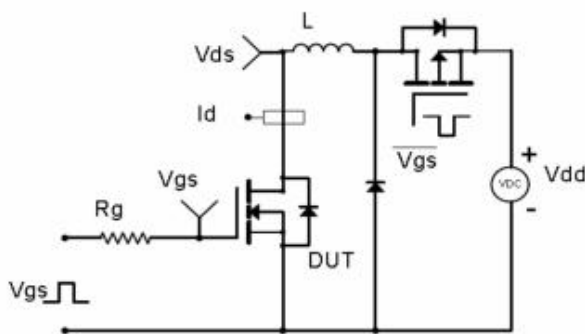

Diode Recovery Test Circuit & Waveforms

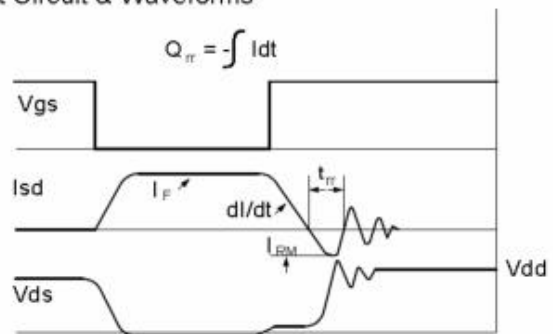
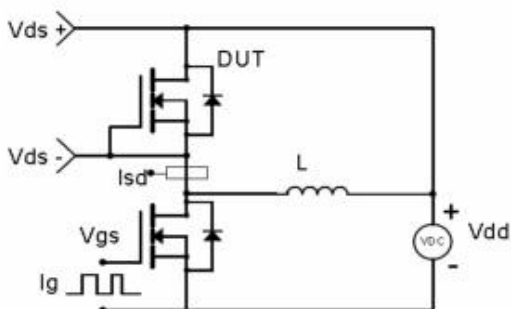

Typical Electronic and Thermal Characteristics

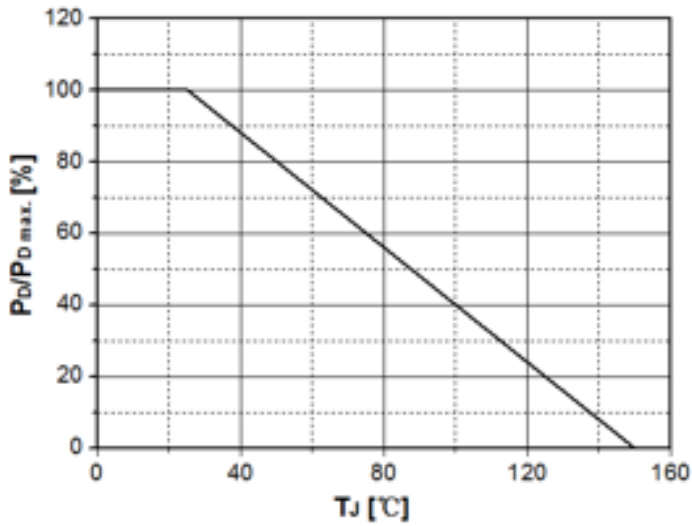

Figure 1. Power Dissipation Derating Curve

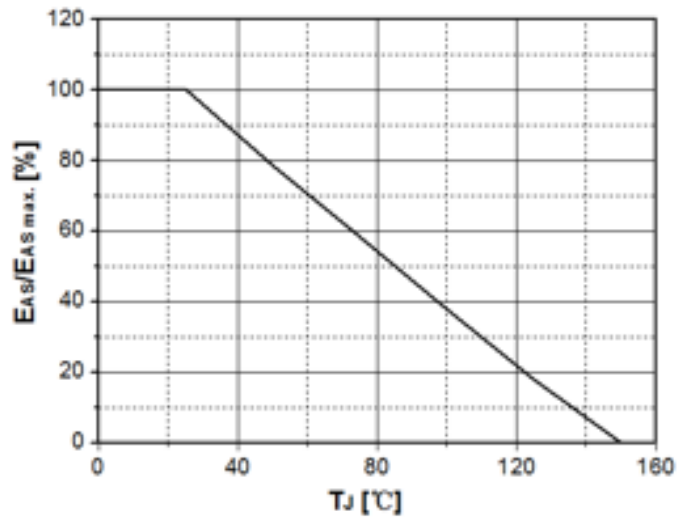

Figure 2. Avalanche Energy Derating Curve vs. Junction Temperature

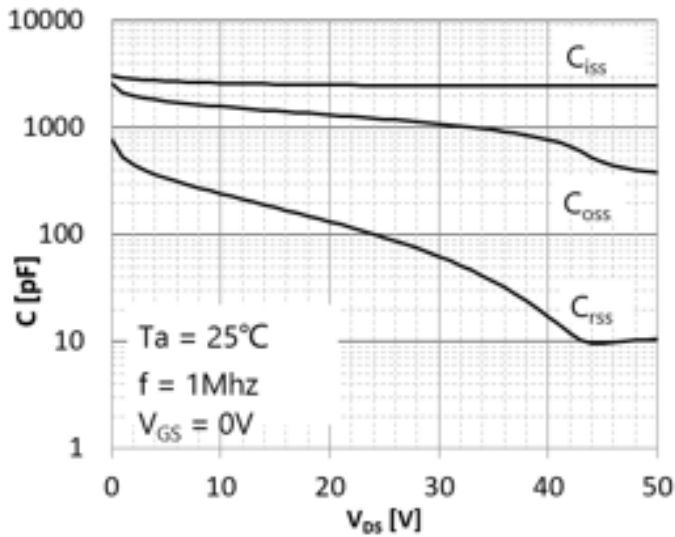

Figure 3. Capacitance Characteristics

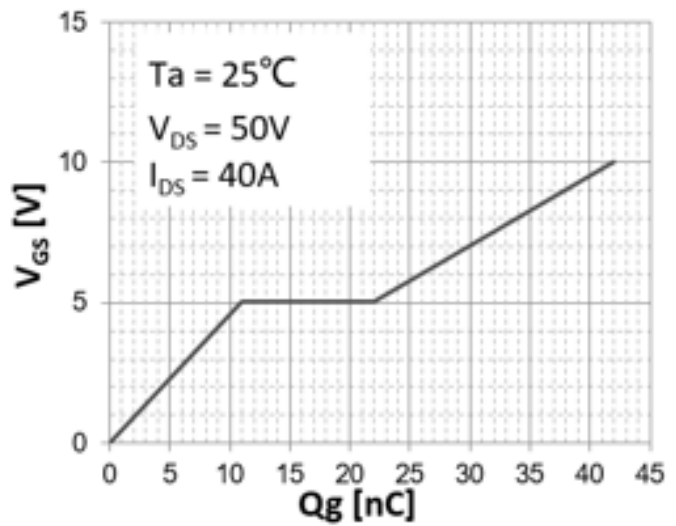
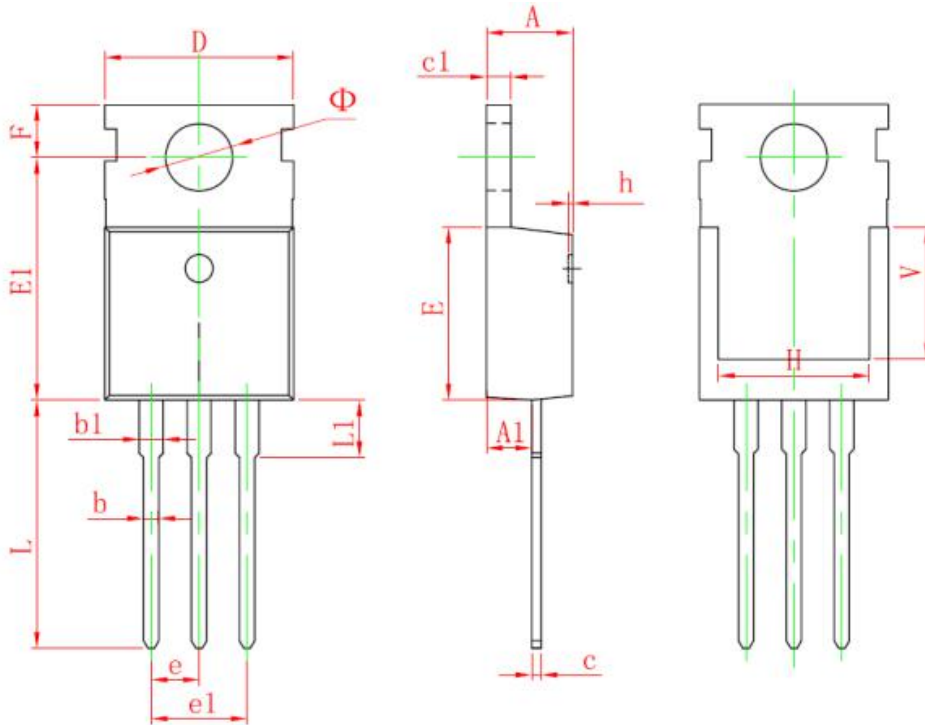

Figure 4. Gate Charge Characteristics

APG082N01

N-Channel Enhancement Mosfet

TO220C Package Information



Symbol	Dimensions In Millimeters		Dimensions In Inches	
	Min.	Max.	Min.	Max.
A	4.400	4.600	0.173	0.181
A1	2.250	2.550	0.089	0.100
b	0.710	0.910	0.028	0.036
b1	1.170	1.370	0.046	0.054
c	0.330	0.650	0.013	0.026
c1	1.200	1.400	0.047	0.055
D	9.910	10.250	0.390	0.404
E	8.950	9.750	0.352	0.384
E1	12.650	13.050	0.498	0.514
e	2.540 TYP.		0.100 TYP.	
e1	4.980	5.180	0.196	0.204
F	2.650	2.950	0.104	0.116
H	7.900	8.100	0.311	0.319
h	0.000	0.300	0.000	0.012
L	12.900	13.400	0.508	0.528
L1	2.850	3.250	0.112	0.128
V	6.900 REF.		0.276 REF.	
Φ	3.400	3.800	0.134	0.150