

Feature

- -60V,-25A
 $R_{DS(ON)} < 60m\Omega @ V_{GS} = -10V$ TYP: 52m Ω
 $R_{DS(ON)} < 80m\Omega @ V_{GS} = -4.5V$ TYP: 64m Ω
- Advanced Trench Technology
- Lead free product is acquired
- Excellent $R_{DS(ON)}$ and Low Gate Charge
- $T_{jmax} = 175^{\circ}C$
- AEC-Q101 qualified

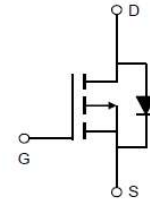

Schematic Diagram

Application

- PWM applications
- Load Switch
- Power management

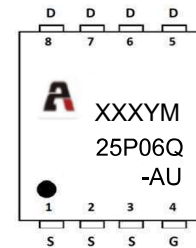

Marking and pin Assignment

Package Marking and Ordering Information

Device Marking	Device	Device Package	Reel Size	Tape width	Quantity (PCS)
25P06Q-AU	AP25P06Q-AU	PDFN3X3	13 inch	-	5000

ABSOLUTE MAXIMUM RATINGS ($T_J = 25^{\circ}C$ unless otherwise noted)

Parameter	Symbol	Value	Unit
Drain-Source Voltage	V_{DS}	-60	V
Gate-Source Voltage	V_{GS}	± 20	V
Continuous Drain Current ($T_c = 25^{\circ}C$)	I_D	-25	A
Continuous Drain Current ($T_c = 100^{\circ}C$)	I_D	-19	A
Pulsed Drain Current ⁽¹⁾	I_{DM}	-100	A
Single Pulsed Avalanche Energy ⁽⁴⁾	E_{AS}	50	mJ
Power Dissipation	P_D	42	W
Thermal Resistance from Junction to Case	$R_{\theta JC}$	3.5	$^{\circ}C/W$
Thermal Resistance- Junction to Ambient	$R_{\theta JA}$	52	$^{\circ}C/W$
Junction Temperature	T_J	175	$^{\circ}C$
Storage Temperature	T_{STG}	-55~ +175	$^{\circ}C$

MOSFET ELECTRICAL CHARACTERISTICS(T_J=25°C unless otherwise noted)

Parameter	Symbol	Test Condition	Min	Type	Max	Unit
Static Characteristics						
Drain-source breakdown voltage	V _{(BR)DSS}	V _{GS} = 0V, I _D = -250μA	-60	-	-	V
Zero gate voltage drain current	I _{DSS}	V _{DS} = -60V, V _{GS} = 0V	-	-	1	μA
Gate-body leakage current	I _{GSS}	V _{GS} = ±20V, V _{DS} = 0V	-	-	±100	nA
Gate threshold voltage ⁽³⁾	V _{GS(th)}	V _{DS} = V _{GS} , I _D = -250μA	-1.0	-1.5	-2.0	V
Drain-source on-resistance ⁽³⁾	R _{DS(on)}	V _{GS} = -10V, I _D = -10A	-	52	60	mΩ
		V _{GS} = -4.5V, I _D = -5A	-	64	80	
Dynamic characteristics						
Input Capacitance	C _{iss}	V _{DS} = -30V, V _{GS} = 0V, f = 1MHz	-	1408	-	pF
Output Capacitance	C _{oss}		-	64	-	
Reverse Transfer Capacitance	C _{rss}		-	47	-	
Switching characteristics						
Turn-on delay time	t _{d(on)}	V _{DD} = -30V, I _D = -10A, R _L = 3Ω V _{GS} = -4.5V, R _G = 4.5Ω	-	14	-	ns
Turn-on rise time	t _r		-	51	-	
Turn-off delay time	t _{d(off)}		-	197	-	
Turn-off fall time	t _f		-	112	-	
Total Gate Charge	Q _g	V _{DS} = -30V, I _D = -10A, V _{GS} = -10V	-	23	-	nC
Gate-Source Charge	Q _{gs}		-	6.5	-	
Gate-Drain Charge	Q _{gd}		-	3	-	
Source-Drain Diode characteristics						
Diode Forward voltage ⁽²⁾	V _{DS}	V _{GS} = 0V, I _S = -10A	-	-	-1.3	V
Diode Forward current ⁽³⁾	I _S		-	-	-25	A
Body Diode Reverse Recovery Time	t _{rr}	T _J = 25°C, I _F = -10A, di/dt = 100A/us		25		ns
Body Diode Reverse Recovery Charge	Q _{rr}	T _J = 25°C, I _F = -10A, di/dt = 100A/us		7.5		nc

Notes:

1. Repetitive Rating: pulse width limited by maximum junction temperature
2. Pulse Test: pulse width ≤ 300μs, duty cycle ≤ 2%
3. Surface Mounted on FR4 Board, t ≤ 10 sec
4. EAS Condition: T_J = 25°C, V_{DD} = -30V, R_G = 25 Ω, L = 0.5mH

Test Circuit

1) E_{AS} Test Circuits

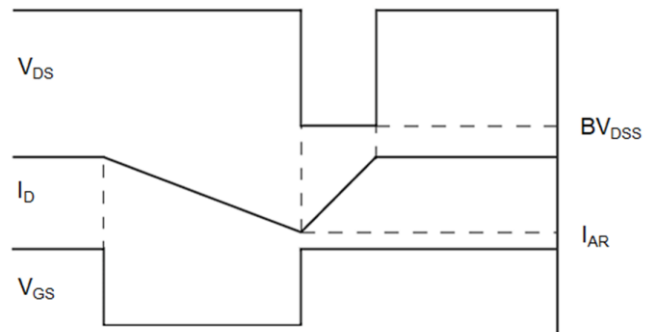
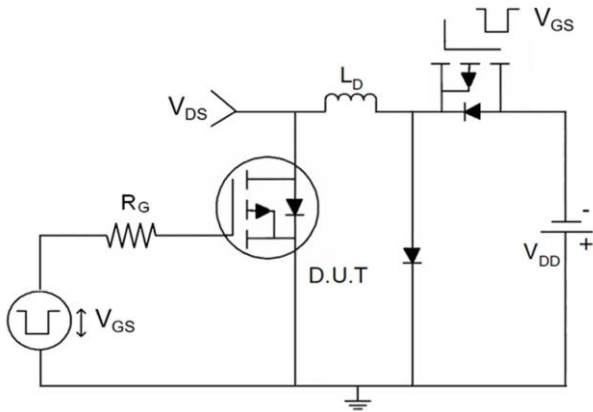

2) Gate Charge Test Circuit

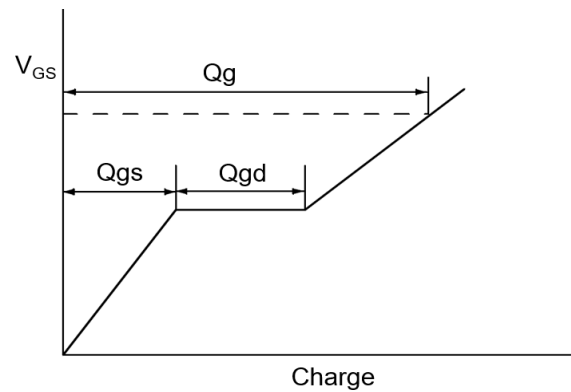
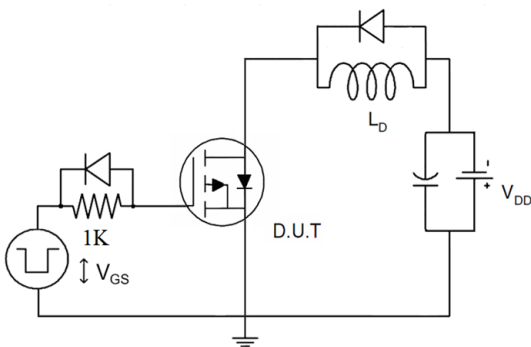

3) Switch Time Test Circuit

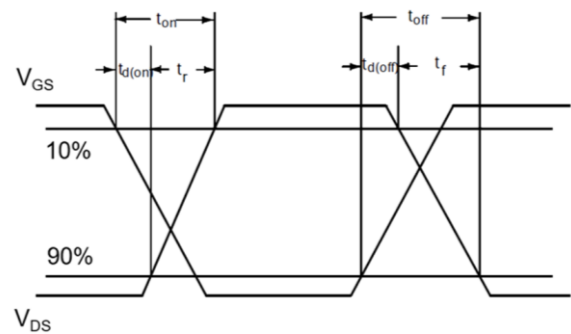
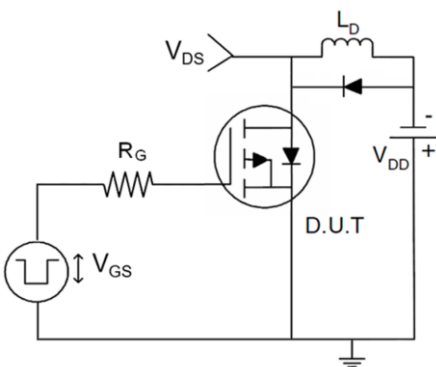

Typical Performance Characteristics

Output Characteristics

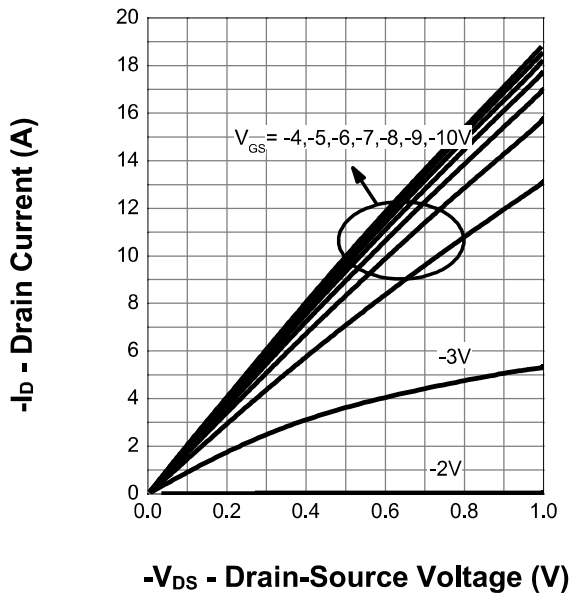

Drain-Source On Resistance

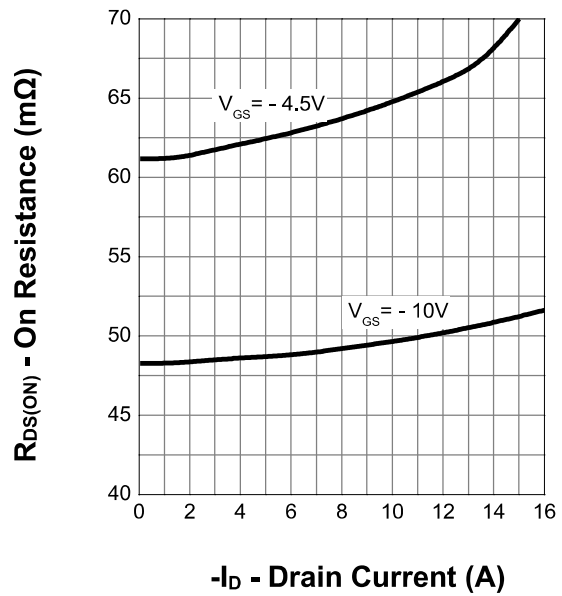

Transfer Characteristics

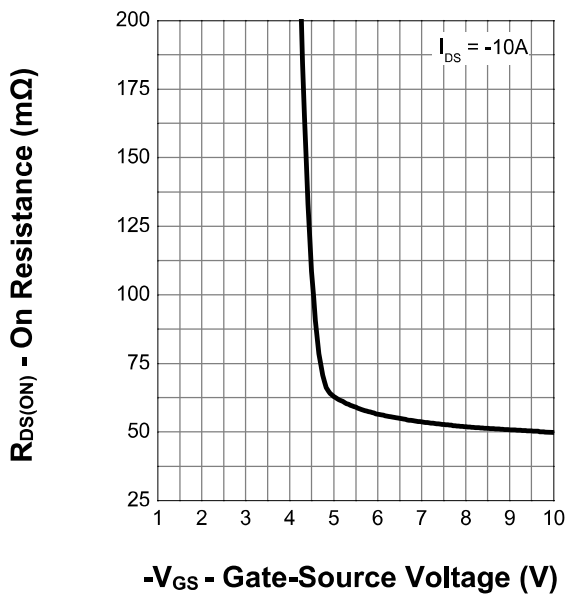

Gate Threshold Voltage

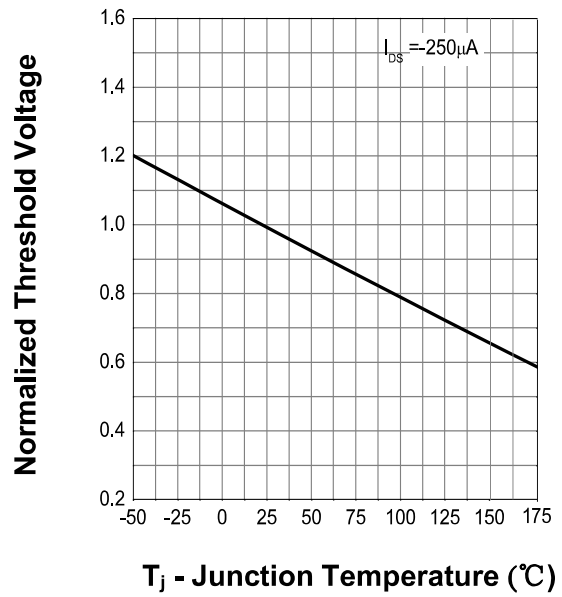

Typical Performance Characteristics

Drain-Source On Resistance

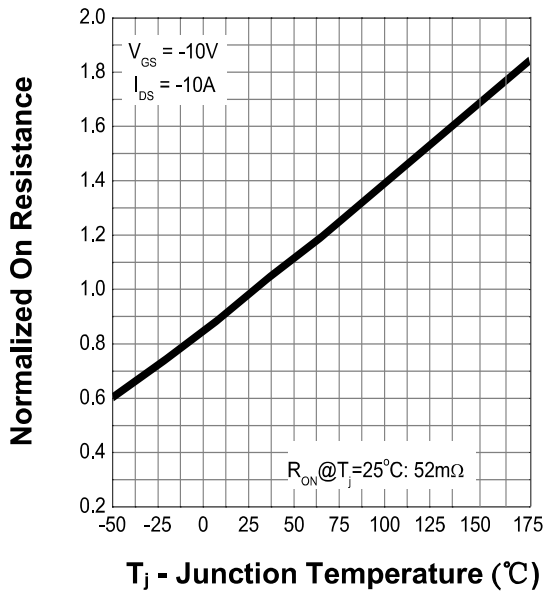

Source-Drain Diode Forward

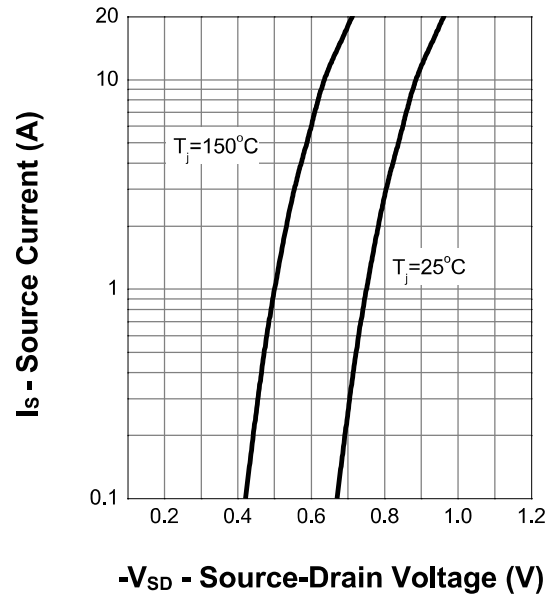

Capacitance

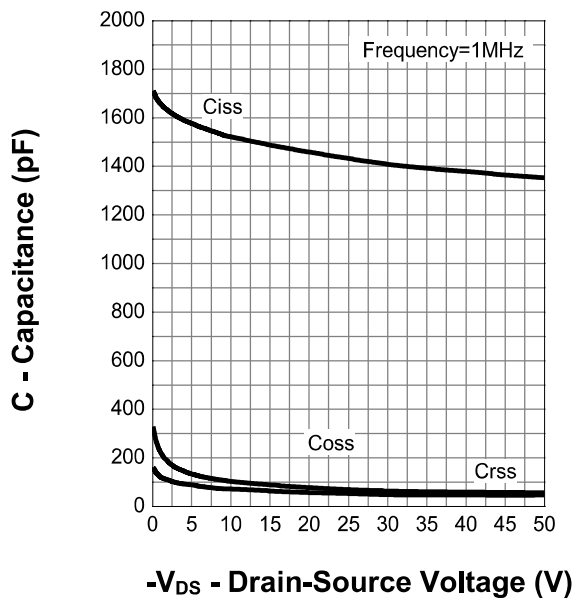

Gate Charge

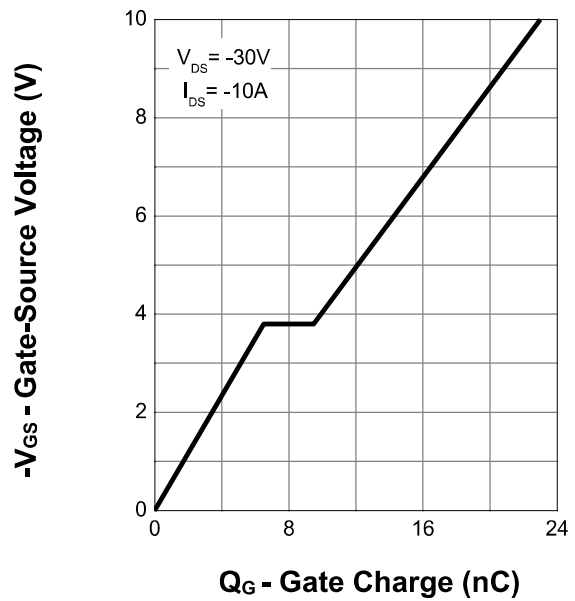

Typical Performance Characteristics

Power Dissipation

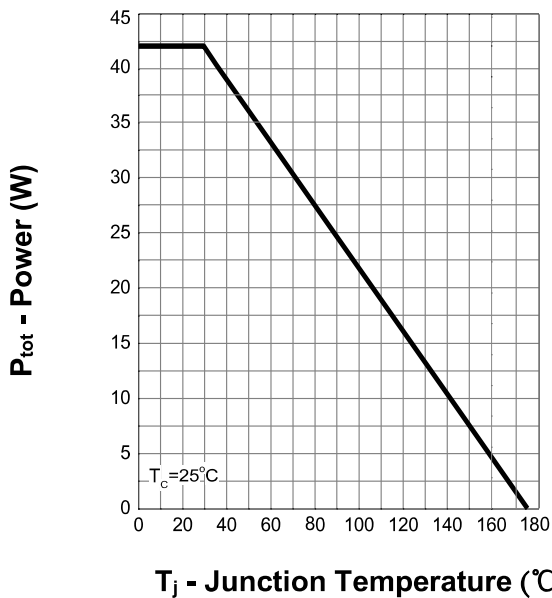

Drain Current

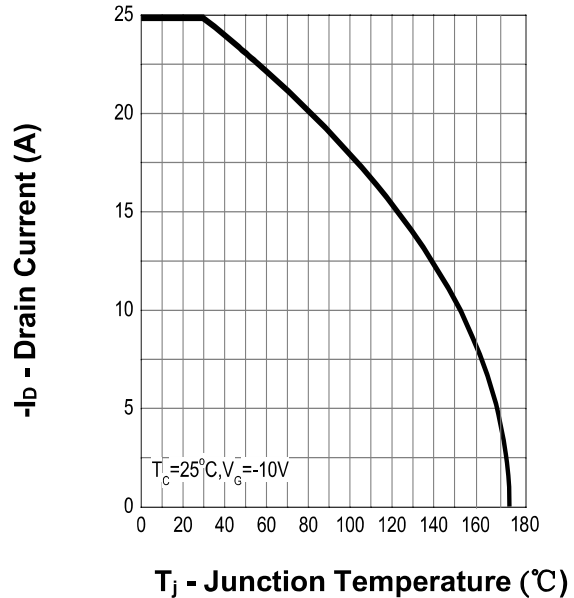

Safe Operation Area

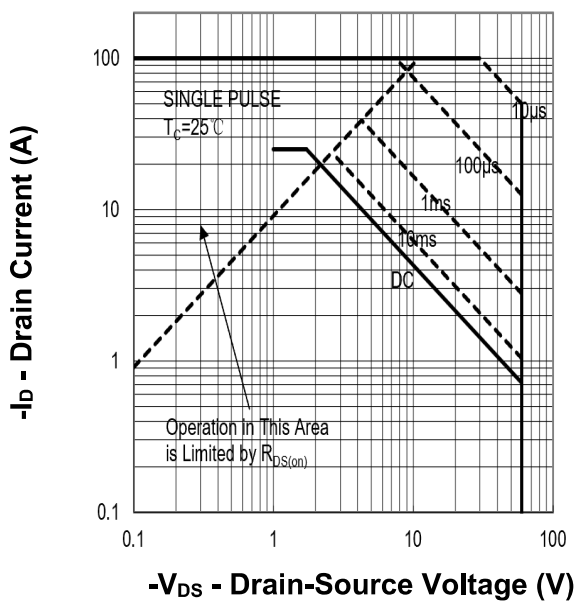

Thermal Transient Impedance

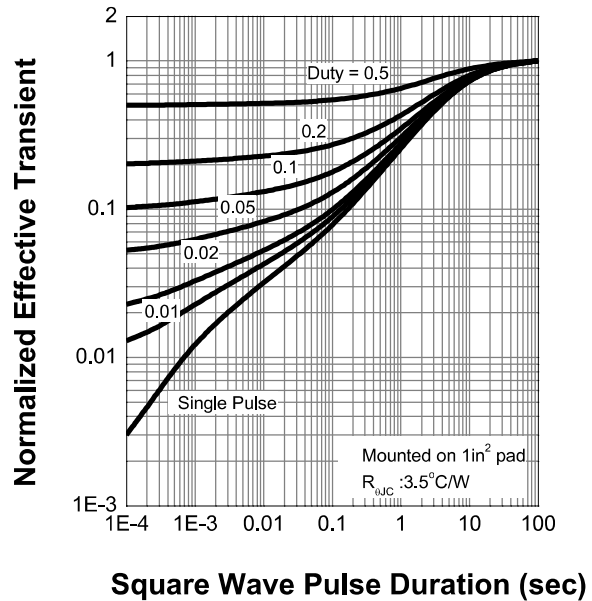

Package Mechanical Data

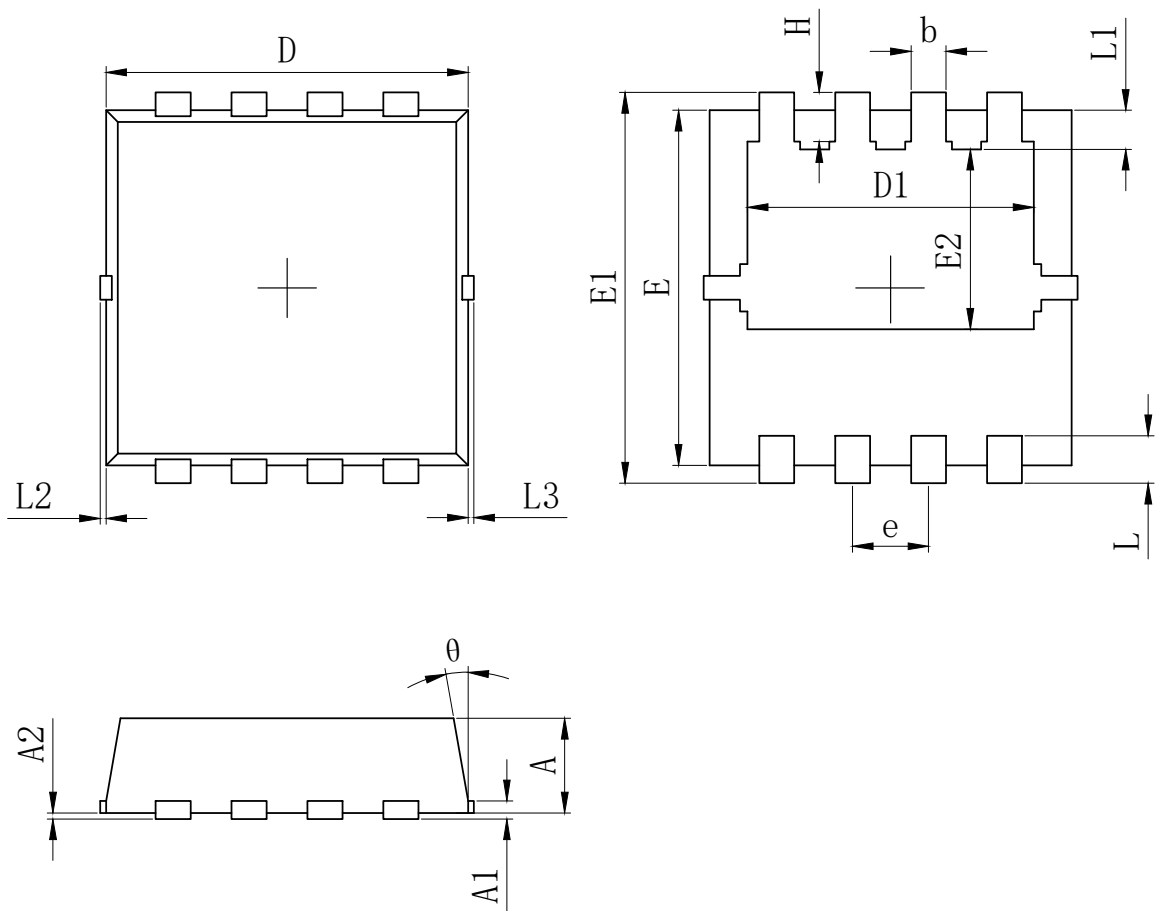

SYMBOL	MILLIMETER		
	MIN	Typ.	MAX
A	0.700	0.800	0.900
A1	0.152 REF.		
A2	0~0.05		
D	3.000	3.100	3.200
D1	2.300	2.450	2.600
E	2.900	3.000	3.100
E1	3.150	3.300	3.450
E2	1.320	1.520	1.720
b	0.200	0.300	0.400
e	0.550	0.650	0.750
L	0.300	0.400	0.500
L1	0.180	0.330	0.480
L2	0~0.100		
L3	0~0.100		
H	0.315	0.415	0.515
θ	8°	10°	12°

Revision History

Revision	Release	Remark
V1.0	2023/06/06	Initial Release
V1.1	2023/11/24	Update The Curve on page4/5/6

Disclaimer

The information given in this document describes the independent performance of the product, but similar performance is not guaranteed under other working conditions, and cannot be guaranteed when installed with other products or equipment. To achieve the required performance of the product in actual scenarios, the customer should conduct a complete application test to assess the functionality of the product.

Allpower assumes no responsibility for equipment failures result from using products at values that exceed the ratings, operating conditions, or other parameters listed in the product specifications.

The product described in this specification is not applicable for aerospace or other applications which requires high reliability. Customers using or selling these products for use in medical, life-saving, or life-sustaining applications do so at their own risk and agree to fully indemnify.

Due to product or technical improvements, the information described or contained herein may be changed without prior notice.