

Features

- -40V, -100A
 $R_{DS(ON)} < 6.0m\ \Omega @ V_{GS} = -10V$ TYP:5.2m Ω
 $R_{DS(ON)} < 8.3m\ \Omega @ V_{GS} = -4.5V$ TYP:6.7m Ω
- Advanced Trench Technology
- High Power and current handling capability
- Lead free product is acquired

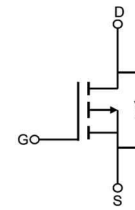

Schematic Diagram



Marking and pin assignment

Applications

- Load Switch
- PWM Application
- Power management

Package Marking and Ordering Information

Device Marking	Device	Device Package	Reel Size	Tape width	Quantity (PCS)
100P04K	AP100P04K	TO-252	13inch	-	2500

ABSOLUTE MAXIMUM RATINGS ($T_J = 25^\circ\text{C}$ unless otherwise noted)

Parameter	Symbol	Value	Unit
Drain-Source Voltage	V_{DS}	-40	V
Gate-Source Voltage	V_{GS}	± 20	V
Continuous Drain Current ($T_C = 25^\circ\text{C}$)	I_D	-100	A
Continuous Drain Current ($T_C = 100^\circ\text{C}$)	I_D	-60	A
Pulsed Drain Current ⁽¹⁾	I_{DM}	-400	A
Single Pulsed Avalanche Energy ⁽²⁾	E_{AS}	576	mJ
Drain Power Dissipation	P_D	90	W
Thermal Resistance from Junction to Case ⁽²⁾	$R_{\theta JC}$	1.4	$^\circ\text{C}/\text{W}$
Thermal Resistance from Junction to Ambient	$R_{\theta JA}$	56	$^\circ\text{C}/\text{W}$
Junction Temperature	T_J	150	$^\circ\text{C}$
Storage Temperature	T_{STG}	-55~ +150	$^\circ\text{C}$

MOSFET ELECTRICAL CHARACTERISTICS(T_J=25°C unless otherwise noted)

Parameter	Symbol	Test Condition	Min	Type	Max	Unit
Static Characteristics						
Drain-source breakdown voltage	V _{(BR)DSS}	V _{GS} = 0V, I _D = -250μA	-40	-	-	V
Zero gate voltage drain current	I _{DSS}	V _{DS} = -40V, V _{GS} = 0V	-	-	-1	μA
Gate-body leakage current	I _{GSS}	V _{GS} = ±20V, V _{DS} = 0V	-	-	±100	nA
Gate threshold voltage	V _{GS(th)}	V _{DS} = V _{GS} , I _D = -250μA	-1.0	-1.7	-2.5	V
Drain-source on-resistance ⁽³⁾	R _{DS(on)}	V _{GS} = -10V, I _D = -20A	-	5.2	6.0	mΩ
		V _{GS} = -4.5V, I _D = -20A		6.7	8.3	mΩ
Dynamic characteristics						
Input Capacitance	C _{iSS}	V _{DS} = -20V, V _{GS} = 0V, f = 1.0MHz	-	6638	-	pF
Output Capacitance	C _{oSS}		-	545	-	
Reverse Transfer Capacitance	C _{rSS}		-	345	-	
Gate resistance	R _g	V _{DS} = 0V, V _{GS} = 0V, f = 1.0MHz		2.2		Ω
Switching characteristics						
Turn-on delay time	t _{d(on)}	V _{DS} = -20V, I _D = -20A, R _G = 3Ω, V _G = -10V	-	16	-	ns
Turn-on rise time	t _r		-	17	-	
Turn-off delay time	t _{d(off)}		-	68	-	
Turn-off fall time	t _f		-	31	-	
Total Gate Charge	Q _g	V _{DS} = -20V, I _D = -20A, V _{GS} = -10V	-	118	-	nC
Gate-Source Charge	Q _{gs}		-	13	-	
Gate-Drain Charge	Q _{gd}		-	22	-	
Source-Drain Diode characteristics						
Diode Forward voltage ^(a)	V _{SD}	T _J = 25°C, V _{GS} = 0V, I _S = -20A	-	-	-1.2	V
Diode Forward current	I _S	T _C = 25°C	-	-	-100	A
Body Diode Reverse Recovery Time	t _{rr}	T _J = 25°C, I _F = -20A, di/dt = 100A/us		24		ns
Body Diode Reverse Recovery Charge	Q _{rr}	T _J = 25°C, I _F = -20A, di/dt = 100A/us		140		nc

Notes:

- a) Repetitive Rating: Pulse Width Limited by Maximum Junction Temperature
- b) EAS condition: T_J = 25°C, V_{DD} = -15V, V_G = -10V, I_{AS} = -48A, R_G = 25Ω, L = 0.5mH
- c) Pulse Test: Pulse Width ≤ 300μs, Duty Cycle ≤ 0.5%

Typical Electrical And Thermal Characteristics (Curves)

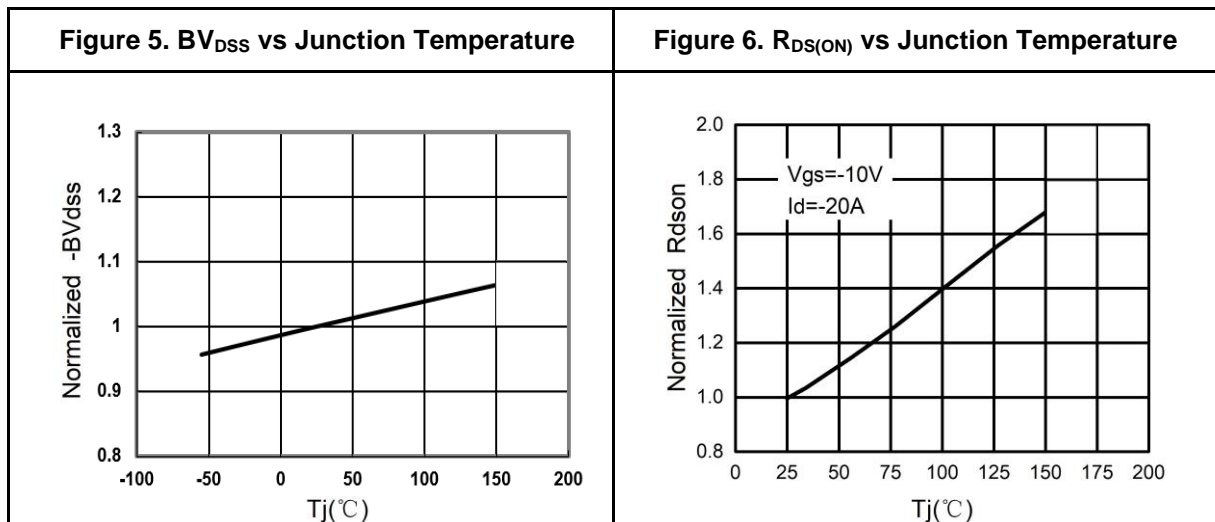
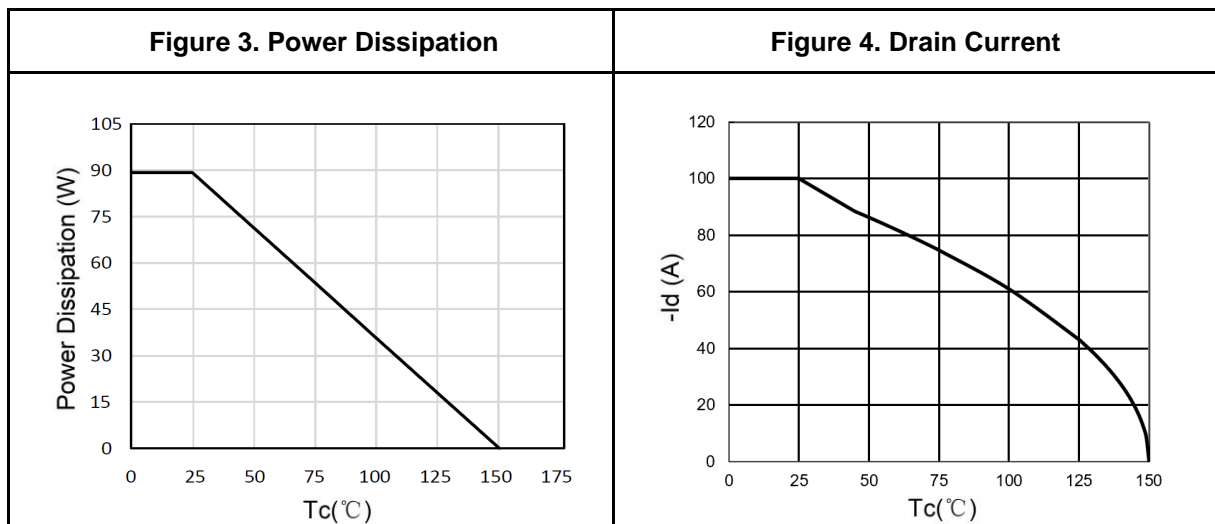
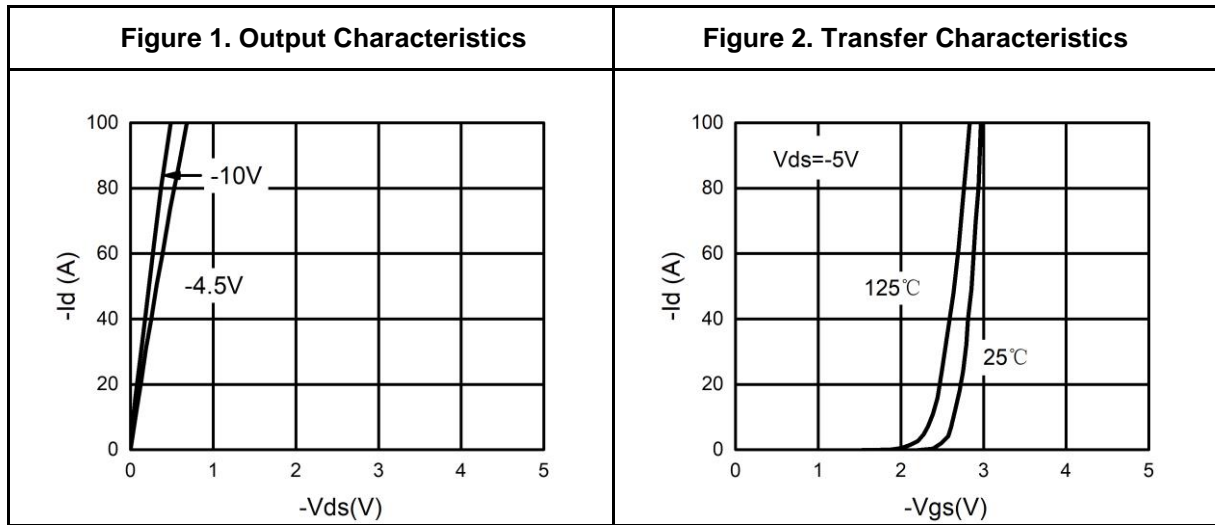

Typical Electrical And Thermal Characteristics (Curves)

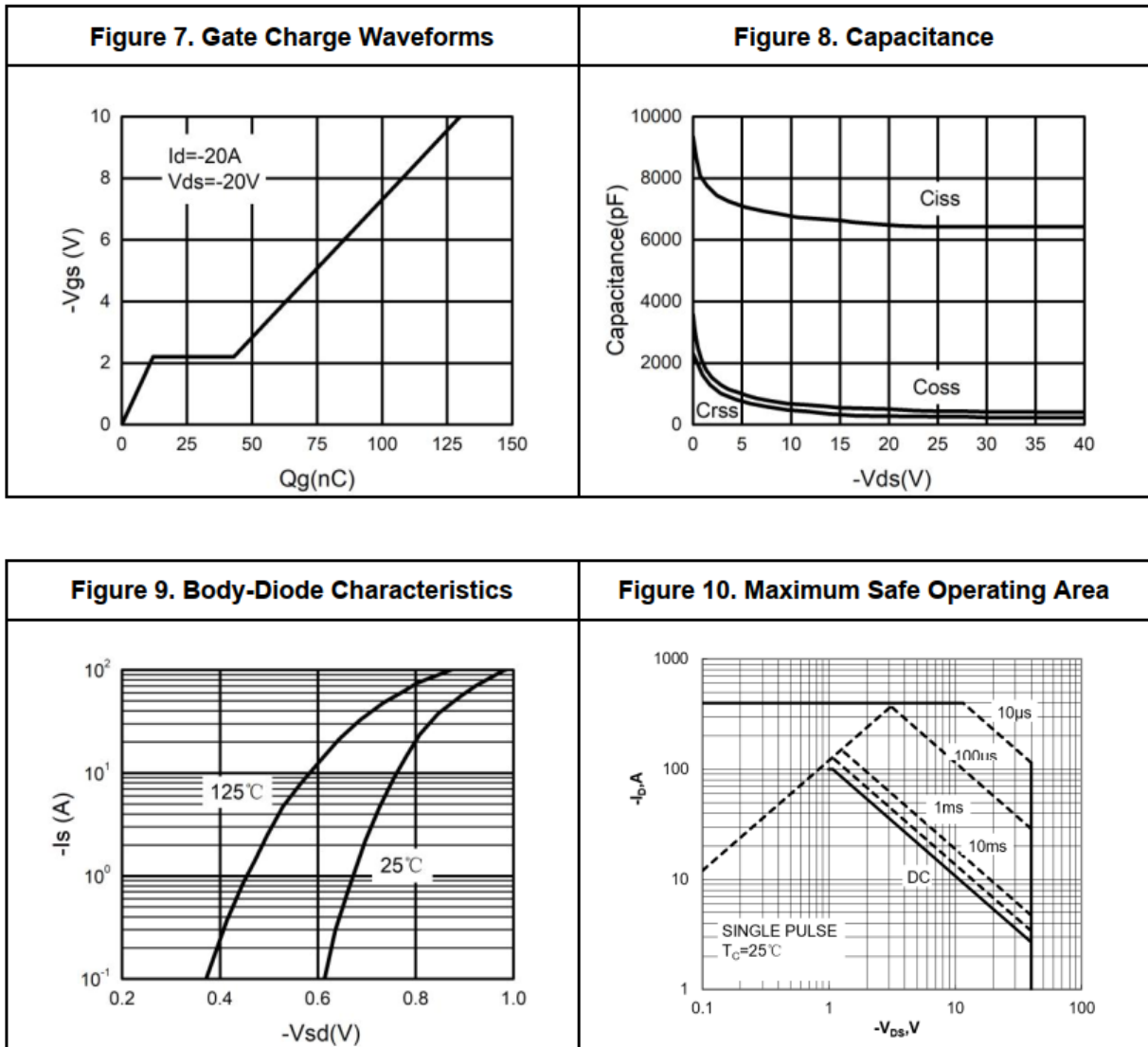
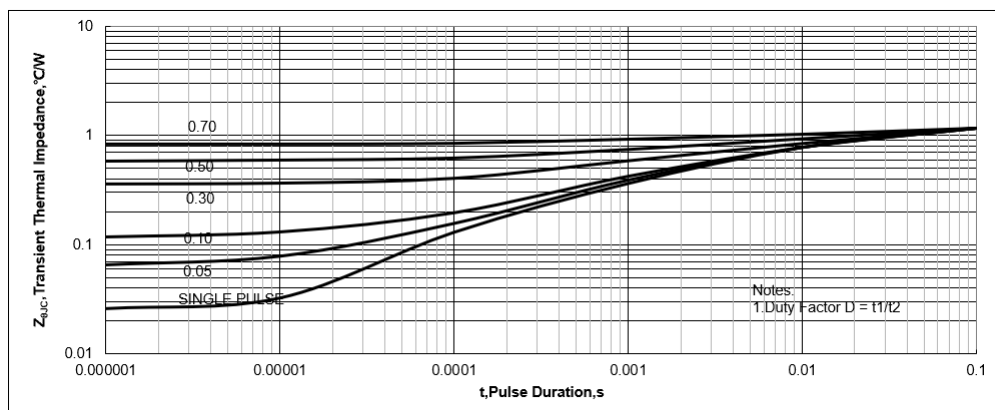
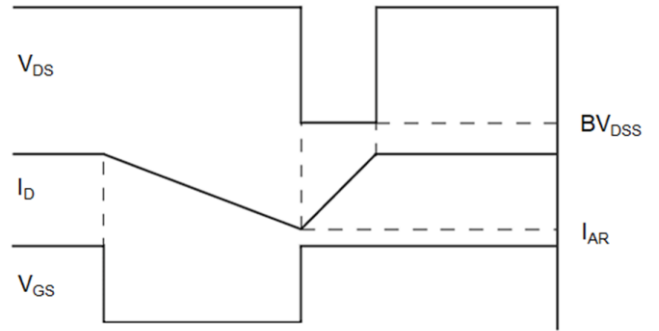
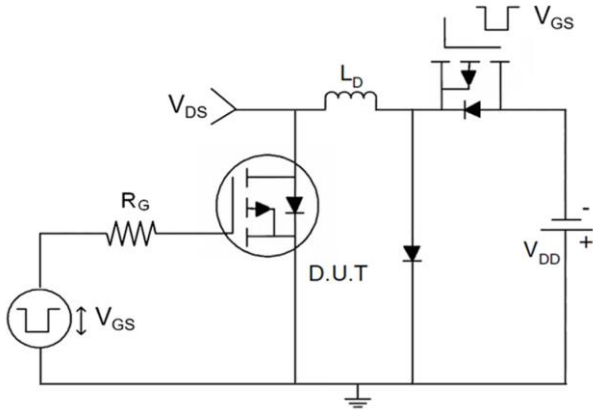

Figure.11: Maximum Effective Transient Thermal Impedance, Junction-to-Case



Test Circuit

1) E_{AS} Test Circuits



2) Gate Charge Test Circuit

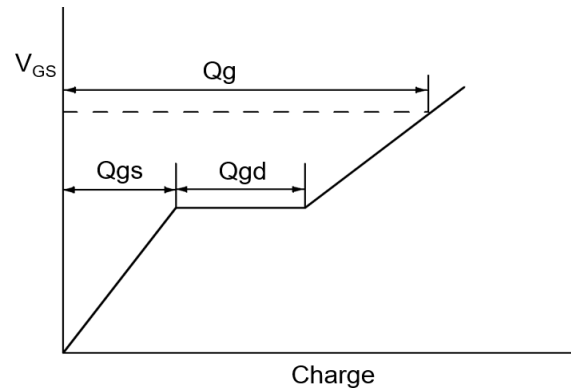
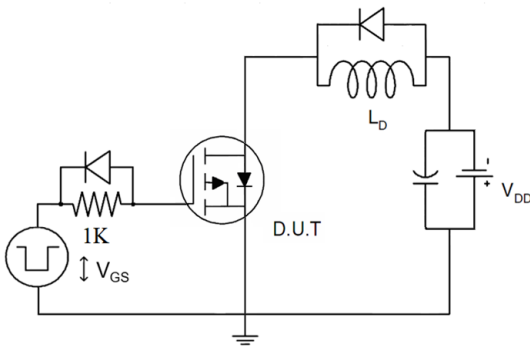

3) Switch Time Test Circuit

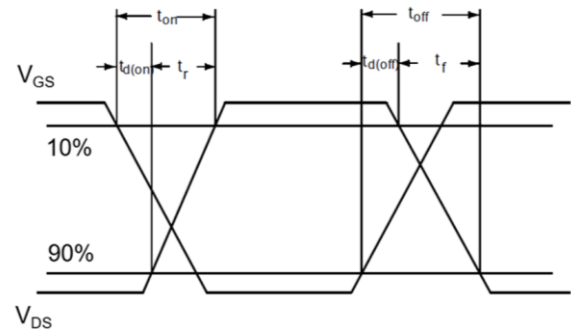
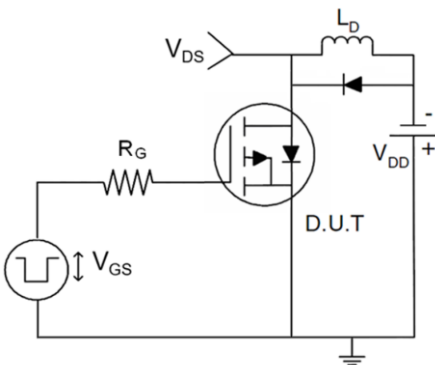

TO-252 Package Information

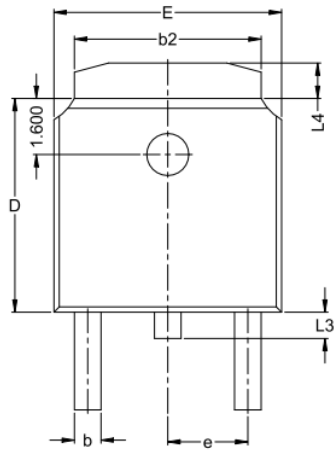

TOP VIEW

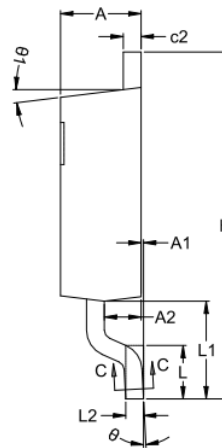

SIDE VIEW(Right)

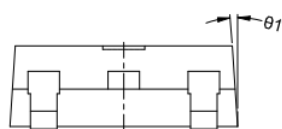

SIDE VIEW(Front)

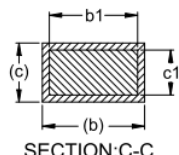

SECTION:C-C

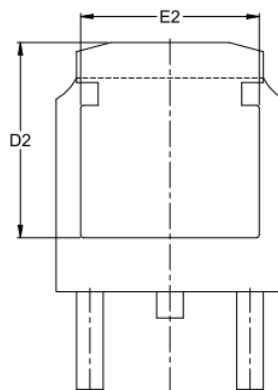

OPTION 1
BOTTOM VIEW

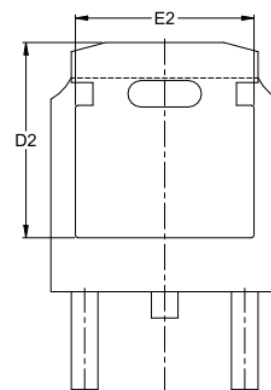

OPTION 2
BOTTOM VIEW

DIM SYMBOL	MIN.	NOM.	MAX.
A	2.200	2.300	2.400
A1	0.000	0.070	0.130
A2	0.950	1.050	1.150
b	0.700	0.800	0.900
b1	0.660	0.760	0.860
b2	5.134	5.334	5.534
c	0.448	0.548	0.648
c1	0.458	0.508	0.558
c2	0.448	0.548	0.648
D	6.000	6.100	6.200
D2	5.372	5.572	5.772
E	6.400	6.500	6.600
E2	4.900	5.100	5.300
e	2.286 BSC.		
H	9.700	9.900	10.100
L	1.380	1.525	1.725
L1	2.588	2.788	2.988
L2	0.508 BSC.		
L3	0.600	0.750	0.950
L4	0.812	1.012	1.212
θ	1°	3°	5°
θ_1	6°	7°	8°

Revision History

Revision	Release	Remark
V1.0	2023/02/06	Initial Release
V1.1	2024/11/20	Update POD

Disclaimer

The information given in this document describes the independent performance of the product, but similar performance is not guaranteed under other working conditions, and cannot be guaranteed when installed with other products or equipment. To achieve the required performance of the product in actual scenarios, the customer should conduct a complete application test to assess the functionality of the product.

Allpower assumes no responsibility for equipment failures result from using products at values that exceed the ratings, operating conditions, or other parameters listed in the product specifications.

The product described in this specification is not applicable for aerospace or other applications which requires high reliability. Customers using or selling these products for use in medical, life-saving, or life-sustaining applications do so at their own risk and agree to fully indemnify.

Due to product or technical improvements, the information described or contained herein may be changed without prior notice.